

Service Manual



SPG600 & SPG300 Sync Pulse Generators

071-1342-02

Warning

The servicing instructions are for use by qualified personnel only. To avoid personal injury, do not perform any servicing unless you are qualified to do so. Refer to all safety summaries prior to performing service.

www.tektronix.com

Copyright © Tektronix. All rights reserved. Licensed software products are owned by Tektronix or its suppliers and are protected by United States copyright laws and international treaty provisions.

Use, duplication, or disclosure by the Government is subject to restrictions as set forth in subparagraph (c)(1)(ii) of the Rights in Technical Data and Computer Software clause at DFARS 252.227-7013, or subparagraphs (c)(1) and (2) of the Commercial Computer Software - Restricted Rights clause at FAR 52.227-19, as applicable.

Tektronix products are covered by U.S. and foreign patents, issued and pending. Information in this publication supercedes that in all previously published material. Specifications and price change privileges reserved.

TEKTRONIX and TEK are registered trademarks of Tektronix, Inc.

Contacting Tektronix

Tektronix, Inc.
14200 SW Karl Braun Drive or P.O. Box 500
Beaverton, OR 97077 USA

For product information, sales, service, and technical support:

- In North America, call 1-800-833-9200.
- Worldwide, visit www.tektronix.com to find contacts in your area.

Warranty 2

Tektronix warrants that this product will be free from defects in materials and workmanship for a period of one (1) year from the date of shipment. If any such product proves defective during this warranty period, Tektronix, at its option, either will repair the defective product without charge for parts and labor, or will provide a replacement in exchange for the defective product. Parts, modules and replacement products used by Tektronix for warranty work may be new or reconditioned to like new performance. All replaced parts, modules and products become the property of Tektronix.

In order to obtain service under this warranty, Customer must notify Tektronix of the defect before the expiration of the warranty period and make suitable arrangements for the performance of service. Customer shall be responsible for packaging and shipping the defective product to the service center designated by Tektronix, with shipping charges prepaid. Tektronix shall pay for the return of the product to Customer if the shipment is to a location within the country in which the Tektronix service center is located. Customer shall be responsible for paying all shipping charges, duties, taxes, and any other charges for products returned to any other locations.

This warranty shall not apply to any defect, failure or damage caused by improper use or improper or inadequate maintenance and care. Tektronix shall not be obligated to furnish service under this warranty a) to repair damage resulting from attempts by personnel other than Tektronix representatives to install, repair or service the product; b) to repair damage resulting from improper use or connection to incompatible equipment; c) to repair any damage or malfunction caused by the use of non-Tektronix supplies; or d) to service a product that has been modified or integrated with other products when the effect of such modification or integration increases the time or difficulty of servicing the product.

THIS WARRANTY IS GIVEN BY TEKTRONIX IN LIEU OF ANY OTHER WARRANTIES, EXPRESS OR IMPLIED. TEKTRONIX AND ITS VENDORS DISCLAIM ANY IMPLIED WARRANTIES OF MERCHANTABILITY OR FITNESS FOR A PARTICULAR PURPOSE. TEKTRONIX' RESPONSIBILITY TO REPAIR OR REPLACE DEFECTIVE PRODUCTS IS THE SOLE AND EXCLUSIVE REMEDY PROVIDED TO THE CUSTOMER FOR BREACH OF THIS WARRANTY. TEKTRONIX AND ITS VENDORS WILL NOT BE LIABLE FOR ANY INDIRECT, SPECIAL, INCIDENTAL, OR CONSEQUENTIAL DAMAGES IRRESPECTIVE OF WHETHER TEKTRONIX OR THE VENDOR HAS ADVANCE NOTICE OF THE POSSIBILITY OF SUCH DAMAGES.

Table of Contents

General Safety Summary	ix
Service Safety Summary	xi
Preface	xiii
About This Manual	xiii
Manual Conventions	xiv
Finding Other Information	xiv
Introduction	xv
Performance Check Interval	xv
Strategy for Servicing	xvi
Tektronix Service Offerings	xvii

Specifications

Product Overview	1-1
Specifications	1-3
General Characteristics	1-3
Certifications and Compliances	1-12

Operating Information

Installation	2-1
Supplying Operating Power	2-1
Operating Environment	2-4
Applying and Interrupting Power	2-4
Repackaging Instructions	2-5
Installed Options	2-5
Menus	2-7
Video Menu	2-7
Audio Menu	2-16
Genlock Menu	2-20
System Menu	2-22

Theory of Operation

Theory of Operation	3-1
A10 Main Board (SPG600) and A50 Main Board (SPG300)	3-1
A20 Front-Panel Board	3-3
Power Supply Module	3-4
A30 Analog Board (SPG600 Option 02) and A50 Analog Board (SPG300)	3-4
A40 SDI Board (SPG600 Option 03)	3-4

Performance Verification

Performance Verification	4-1
Preparation for Performance Verification	4-1
Equipment Required	4-1
Calibration Data Report	4-2
Performance Verification Procedures	4-4

Adjustment

Adjustment Procedure	5-1
Requirement for Adjustment	5-1
Equipment Required	5-1
Master Clock Frequency Adjustment	5-2

Maintenance

Maintenance	6-1
Related Maintenance Procedures	6-1
Preparation	6-2
Inspection and Cleaning	6-2
Removal and Installation Procedures	6-5
Preparation	6-5
Access Procedure	6-12
Procedures for SPG600 External Modules	6-13
Procedure for SPG600 Internal Modules	6-17
Procedures for SPG300 External Modules	6-23
Procedures for SPG300 Internal Modules	6-27
Setting Main Board Parameters after Replacement	6-33
Setting the Instrument Serial Number	6-33
Installing the Option Key (Option 01 Only)	6-34
Setting the Date and Time	6-34
Troubleshooting	6-37

Options

Options	7-1
Additional Features	7-1
Service Options	7-1

Electrical Parts List

Electrical Parts List	8-1
------------------------------------	------------

Diagrams

Diagrams	9-1
-----------------------	------------

Mechanical Parts List

Mechanical Parts List	10-1
Parts Ordering Information	10-1
Using the Replaceable Parts List	10-2

List of Figures

Figure 1-1: SPG600 dimensions	1-9
Figure 1-2: SPG300 dimensions	1-10
Figure 2-1: Video menu diagram	2-8
Figure 2-2: Test signal (analog) submenu diagram	2-9
Figure 2-3: Test signal (SDI) submenu diagram	2-10
Figure 2-4: Timing (analog) submenu diagram	2-11
Figure 2-5: Timing (SDI) submenu diagram	2-11
Figure 2-6: Overlay submenu diagram	2-12
Figure 2-7: Logo submenu diagram	2-13
Figure 2-8: ID text submenu diagram	2-14
Figure 2-9: SDI parameters submenu	2-15
Figure 2-10: Audio menu diagram	2-16
Figure 2-11: AES/EBU submenu diagram	2-17
Figure 2-12: Embedded submenu diagram	2-18
Figure 2-13: Audio channel submenu diagram	2-19
Figure 2-14: Genlock menu diagram	2-20
Figure 2-15: Genlock timing submenu diagram	2-21
Figure 2-16: System menu diagram	2-22
Figure 2-17: Preset submenu diagram	2-23
Figure 2-18: Network information submenu diagram	2-24
Figure 2-19: Network setup submenu diagram	2-25
Figure 2-20: GPI submenu diagram	2-26
Figure 2-21: System information submenu diagram	2-27
Figure 2-22: System setup submenu diagram	2-27
Figure 2-23: Configuration submenu diagram	2-28
Figure 4-1: Equipment connection for verifying subcarrier frequency ..	4-4
Figure 4-2: Equipment connections for verifying the genlock function .	4-6
Figure 4-3: Equipment connection for verifying the blanking level	4-9
Figure 4-4: Equipment connection for verifying the serial digital outputs	4-12
Figure 4-5: Initial equipment connection for verifying the serial digital audio outputs	4-16

Figure 4-6: Second equipment connection for verifying the serial digital audio outputs	4-17
Figure 4-7: Equipment connection for verifying the XLR digital audio outputs	4-19
Figure 4-8: Equipment connection for verifying the XLR analog audio outputs	4-20
Figure 4-9: Equipment connection for verifying the 48 kHz clock output	4-22
Figure 5-1: Equipment connection for adjusting master clock frequency	5-2
Figure 6-1: Instrument orientation (SPG600)	6-7
Figure 6-2: SPG600 external modules	6-8
Figure 6-3: SPG600 internal modules	6-9
Figure 6-4: SPG300 external modules	6-10
Figure 6-5: SPG300 internal modules	6-11
Figure 6-6: Guide to removal procedures	6-12
Figure 6-7: Top cover removal (SPG600)	6-14
Figure 6-8: Front-panel assembly removal (SPG600)	6-16
Figure 6-9: A30 Analog board removal	6-18
Figure 6-10: A40 SDI board removal	6-19
Figure 6-11: A10 Main board removal	6-21
Figure 6-12: Power supply module removal (SPG600)	6-22
Figure 6-13: Top cover removal (SPG300)	6-24
Figure 6-14: Front-panel assembly removal (SPG300)	6-25
Figure 6-15: A60 Analog board removal	6-28
Figure 6-16: A50 Main board removal	6-29
Figure 6-17: Power supply module removal (SPG300)	6-31
Figure 6-1: Troubleshooting procedure (1)	6-38
Figure 6-2: Troubleshooting procedure (2)	6-39
Figure 6-3: Troubleshooting procedure (3)	6-40
Figure 6-4: Troubleshooting procedure (4)	6-41
Figure 6-5: A10 Main board view of SPG600	6-42
Figure 6-6: A10 Main board view of SPG300	6-43
Figure 9-1: SPG600 block diagram	9-2
Figure 9-2: SPG300 block diagram	9-3

Figure 9-3: Main function block diagram	9-4
Figure 9-4: SPG600 interconnect diagram	9-5
Figure 9-5: SPG300 interconnect diagram	9-6
Figure 10-1: SPG600 external modules	10-5
Figure 10-2: SPG600 internal modules	10-7
Figure 10-3: SPG300 external modules	10-9
Figure 10-4: SPG300 internal modules	10-11

List of Tables

Table 1-1: Output capability of the SPG600 and the SPG300	1-1
Table 1-1: Reference Inputs	1-4
Table 1-2: Analog outputs (standard and Option 02)	1-4
Table 1-3: Serial digital interface (standard and Option 03)	1-5
Table 1-4: AES/EBU audio outputs	1-6
Table 1-5: Analog audio outputs	1-7
Table 1-6: GPI (general purpose interface)	1-7
Table 1-7: SNMP error report	1-7
Table 1-8: AC power source	1-8
Table 1-9: Clearance	1-8
Table 1-10: Mechanical characteristics	1-8
Table 1-11: Environmental characteristics	1-11
Table 1-12: Certifications and compliances	1-12
Table 2-1: Power-cord conductor identification	2-2
Table 2-2: Power cord identification	2-3
Table 4-1: Equipment required for performance verification	4-1
Table 4-2: SPG600 and SPG300 calibration data report	4-2
Table 5-1: Equipment required	5-1
Table 6-1: External inspection check list	6-3
Table 6-2: Internal inspection check list	6-4
Table 6-1: Summary of procedures	6-6
Table 6-2: Tools required for module removal	6-7
Table: Parts list column descriptions	10-2
Table: Manufacturers cross index	10-3
Table: Replaceable parts list (SPG600)	10-4
Table: Replaceable parts list (SPG600)	10-6
Table: Replaceable parts list (SPG300)	10-8
Table: Replaceable parts list (SPG300)	10-10
Table: Replaceable parts list	10-12

General Safety Summary

Review the following safety precautions to avoid injury and prevent damage to this product or any products connected to it. To avoid potential hazards, use this product only as specified.

Only qualified personnel should perform service procedures.

To Avoid Fire or Personal Injury

Use Proper Power Cord. Use only the power cord specified for this product and certified for the country of use.

Ground the Product. This product is grounded through the grounding conductor of the power cord. To avoid electric shock, the grounding conductor must be connected to earth ground. Before making connections to the input or output terminals of the product, ensure that the product is properly grounded.

Observe All Terminal Ratings. To avoid fire or shock hazard, observe all ratings and markings on the product. Consult the product manual for further ratings information before making connections to the product.

Do Not Operate Without Covers. Do not operate this product with covers or panels removed.

Avoid Exposed Circuitry. Do not touch exposed connections and components when power is present.

Do Not Operate With Suspected Failures. If you suspect there is damage to this product, have it inspected by qualified service personnel.

Do Not Operate in Wet/Damp Conditions.

Do Not Operate in an Explosive Atmosphere.

Keep Product Surfaces Clean and Dry.

Provide Proper Ventilation. Refer to the manual's installation instructions for details on installing the product so it has proper ventilation.

No Power Switch. Power supply cord is considered the disconnecting device, disconnect the main power by means of the power cord.

Symbols and Terms **Terms in this Manual.** These terms may appear in this manual:



WARNING. *Warning statements identify conditions or practices that could result in injury or loss of life.*



CAUTION. *Caution statements identify conditions or practices that could result in damage to this product or other property.*

Terms on the Product. These terms may appear on the product:

DANGER indicates an injury hazard immediately accessible as you read the marking.

WARNING indicates an injury hazard not immediately accessible as you read the marking.

CAUTION indicates a hazard to property including the product.

Symbols on the Product. The following symbols may appear on the product:



DANGER
High Voltage



Protective Ground
(Earth) Terminal



ATTENTION
Refer to Manual

Service Safety Summary

Only qualified personnel should perform service procedures. Read this *Service Safety Summary* and the *General Safety Summary* before performing any service procedures.

Do Not Service Alone. Do not perform internal service or adjustments of this product unless another person capable of rendering first aid and resuscitation is present.

Disconnect Power. To avoid electric shock, disconnect the mains power by means of the power cord or, if provided, the power switch.

Use Care When Servicing With Power On. Dangerous voltages or currents may exist in this product. Disconnect power, remove battery (if applicable), and disconnect test leads before removing protective panels, soldering, or replacing components.

To avoid electric shock, do not touch exposed connections.

Preface

This is the service manual for the SPG600 and SPG300 Sync Pulse Generators. This manual contains information needed to service a sync pulse generator to the module level.

About This Manual

This manual is divided into sections, such as the *Specifications* and *Theory of Operation*. Further, some sections are divided into subsections, such as *Product Description* and *Removal and Installation Procedures*.

Sections containing procedures also contain introductions to those procedures. Be sure to read these introductions because they provide information needed to do the service correctly and efficiently. The following are brief descriptions of each manual section.

- *Specifications* contains a description of the sync pulse generator and the characteristics that apply to it.
- *Operating Information* includes general information and operating instructions.
- *Theory of Operation* contains circuit descriptions that support service to the module level.
- *Performance Verification* contains procedures for confirming that a sync pulse generator functions properly and meets warranted characteristics.
- *Adjustment Procedure* contains procedures for adjusting a sync pulse generator to meet warranted characteristics.
- *Maintenance* contains information and procedures for performing preventive and corrective maintenance of a sync pulse generator. These instructions include cleaning, module removal and installation, and fault isolation to the module level.
- *Options* contains descriptions of factory-installed options.
- *Electrical Parts List* contains a statement referring you to *Mechanical Parts List* section, where both the electrical and mechanical modules are listed.
- *Diagrams* contains a block diagram and an interconnection diagram.
- *Mechanical Parts List* includes a table of all replaceable modules, their descriptions, and their Tektronix part numbers.

Manual Conventions

This manual uses certain conventions with which you should become familiar.

Some sections of the manual contain procedures for you to perform. To keep those instructions clear and consistent, this manual uses the following conventions:

- Names of front-panel controls and menus appear in the same case (initial capitals, all uppercase, etc.) in the manual as is used on the sync pulse generator front panel and menu.
- Instruction steps are numbered unless there is only one step.
- **Bold** text refers to specific interface elements that you are instructed to select, click, or clear.

Example: Press the **SYSTEM** button to display the System menu.

- *Italic* text refer to document names or sections. Italics are also used in *NOTES*, *CAUTIONS*, and *WARNINGS*.

Example: Section 10, *Mechanical Parts List*, lists all field replaceable modules by part number.

Modules Throughout this manual, any replaceable component, assembly, or part of the sync pulse generator is referred to generically as a module. In general, a module is an assembly (like a circuit board), rather than a component (like a resistor or an integrated circuit). Sometimes a single component is a module. For example, the chassis of the sync pulse generator is a module.

Safety Symbols and terms related to safety appear in the *General Safety Summary* and *Service Safety Summary* near the beginning of this manual.

Finding Other Information

Other documentation for the sync pulse generator includes:

- The *SPG600 & SPG300 Sync Pulse Generators User Manual* (Tektronix part number 071-1340-XX) contains a tutorial to quickly describe how to operate the sync pulse generator. It also includes an in-depth discussion on how to more completely use the sync pulse generator features.
- The *SPG600 & SPG300 Sync Pulse Generators Quick Reference Manual* (Tektronix part number 071-1341-XX) contains information to enable you to quickly get an overview of front-panel buttons, rear-panel connectors, and menus.

Introduction

This manual contains information needed to properly service the SPG600 and SPG300 Sync Pulse Generators, as well as general information critical to safe and effective servicing.

To prevent personal injury or damage to the sync pulse generator, consider the following before attempting service:

- The procedures in this manual should be performed only by a qualified service person.
- Read the *General Safety Summary* and the *Service Safety Summary*, beginning on page ix.
- Read *Installation* in section 2, *Operating Information*.

When using this manual for servicing, be sure to follow all warnings, cautions, and notes.

Performance Check Interval

Generally, the performance check described in section 4, *Performance Verification*, should be done every 12 months. In addition, a performance check is recommended after module replacement.

If the sync pulse generator does not meet performance criteria, repair is necessary.

Strategy for Servicing

Throughout this manual, the term “module” refers to any field-replaceable component, assembly, or part of the sync pulse generator.

This manual contains all the information needed for periodic maintenance of the sync pulse generator (examples of such information are procedures for checking performance).

Further, this manual contains all information for corrective maintenance down to the module level. To isolate a failure to a module, use the fault isolation procedures found in *Troubleshooting*, part of section 6, *Maintenance*. To remove and replace any field module, follow the instructions in *Removal and Installation Procedures*, also part of section 6. After isolating a faulty module, replace it with a fully-tested module obtained from the factory. Section 10, *Mechanical Parts List*, contains part number and ordering information for all replaceable modules.

Tektronix Service Offerings

Tektronix provides service to cover repair under warranty as well as other services that may provide a cost-effective answer to your service needs.

Whether providing warranty repair service or any of the other services listed below, Tektronix service technicians are well trained to service the sync pulse generator. They have access to the latest information on improvements to the sync pulse generator as well as the latest new options.

Warranty Repair Service

Tektronix warrants this product for one year from date of purchase. The warranty appears after the title page in this manual. Tektronix technicians provide warranty service at most Tektronix service locations. The Tektronix product catalog lists all worldwide service locations or you can visit our web site for service information: www.tektronix.com.

Self Service

Tektronix supports repair to the module level by providing Module Exchange.

Module Exchange. This service reduces down-time for repair by allowing you to exchange most modules for remanufactured ones. Each module comes with a 90-day service warranty.

For More Information. Contact your local Tektronix service center or sales engineer for more information on any of the repair or adjustment services just described.



Specifications

Product Overview

The SPG600 and SPG300 Sync Pulse Generators are designed for high stability master sync operation. The sync pulse generators provide a wide range of accurate reference signals including analog video, analog black burst, serial digital video, serial digital black, and AES/EBU digital audio.

Key Features The sync pulse generator features include:

- High stability internal reference
- Genlocks to the following signals:
 - NTSC/PAL black burst signal
 - 1, 5, 10 MHz, and NTSC/PAL Fsc CW signals
- Serial digital video signal outputs
- AES/EBU serial digital audio outputs (XLR and BNC)
- Overlay a logo or ID text on the color bars or test signal
- Up to 16 channels of embedded audio
- 48 kHz word clock output
- GPI (general purpose interface) for error status report and user preset
- Ethernet (100 BASE-T) interface remote control

Table 1-1: Output capability of the SPG600 and the SPG300

Signal	SPG600 outputs			SPG300 outputs
	Standard	Option 02	Option 03	
Serial digital				
Video	2	2	4	2
BNC audio	4	4	4	None
XLR audio*	2	2	2	2
Analog video	4	8	4	4
48 kHz word clock	Yes	Yes	Yes	Yes

* The XLR outputs can be set to either serial digital or analog audio ports.

Specifications

This section is divided into two subsections. *General Characteristics* lists the electrical, mechanical, and environmental characteristics of the Sync Pulse Generator. *Certifications and Compliances* lists the national and international standards to which the sync pulse generator complies.

General Characteristics

This section lists the electrical, mechanical, and environmental characteristics of the sync pulse generator.

All listed specifications are guaranteed unless labeled with typical. Typical specifications are provided for your convenience but are not guaranteed.

Performance Conditions

The electrical characteristics listed on the following pages are valid under the following conditions:

- The sync pulse generator must be in an environment where the temperature, altitude, humidity, and vibration conditions are within the operating limits described in Table 1-11 on page 1-11.
- The sync pulse generator must have a warm-up period of at least 20 minutes.
- The sync pulse generator must have been calibrated and adjusted at an ambient temperature between +20 °C and +30 °C.
- The sync pulse generator must be operating at an ambient temperature between 0 °C to +40 °C, unless otherwise noted.

Table 1-1: Reference Inputs

Characteristic	Performance requirement	Reference information
Input connector type	75 Ω BNC X 2, loopthrough	
Return loss	> 40 dB to 5 MHz	
Genlock inputs	NTSC Burst 525 Sync PAL Burst PAL Sync CW 1 MHz, 5 MHz, NTSC Burst, PAL Burst, and 10 MHz	
Input requirements		
Reference inputs		
Amplitude	-6 dB to 6 dB	
S/N ratio	> 40 dB	
SCH phase	40 °	
CW amplitude	1 to 2.5 Vp-p	
Pull-in range	\pm 5 ppm	
Jitter		
Burst	< 0.5 °	
Sync	< 1 ns	
Genlock time offset range		
Range	Full color frame	
Resolution	< 0.5 degree of subcarrier	

Table 1-2: Analog outputs (standard and Option 02)

Characteristic	Performance requirement	Reference information
Output connector type	BNC	
Number of outputs		
Standard	4	CH1 to CH4
Option 02 (SPG600 only)	8	CH1 to CH8
Output impedance	75 Ω	
Return loss	> 30 dB to 5 MHz	
Formats		NTSC, NTSC No Setup, and PAL
Burst amplitude accuracy	\pm 5%	
Burst frequency accuracy	\pm 1 Hz of burst frequency	
Burst frequency long term stability	< 1 ppm/year	
Sync amplitude accuracy	\pm 3%	
Blanking level	\pm 50 mV	
SCH phase accuracy	\pm 5 °	

Table 1-2: Analog outputs (standard and Option 02) (cont.)

Characteristic	Performance requirement	Reference information
Timing offset		
Range	Full color frame	
Resolution	< 1/27 MHz	
Output signals		
NTSC and NTSC No Setup		
PAL		
ID text	Maximum 20 characters	Blinking interval: Fast, Slow, or OFF
Logo	Gray scale, 4 level	Blinking interval: Fast, Slow, or OFF

Table 1-3: Serial digital interface (standard and Option 03)

Characteristic	Performance requirement	Reference information
Output connector type	BNC	
Number of outputs		
Standard	2	SDI 1 and SDI 2
Option 03 (SPG600 only)	4	SDI 1, SDI 2, SDI 3, and SDI 4
Output impedance	75 Ω	
Return loss	> 15 dB	
Formats		525-270, 625-270 (270 Mbps)
Signal amplitude, typical	800 mV \pm 10%	
Rise and fall time	0.4 ns to 1.5 ns	20% to 80%
Jitter, typical	< 0.2 UI	
Embedded audio		The settings of the channels 9 to 16 are a copy of those of the channels 1 to 8.
Number of channels	16 (4 groups)	
Frequency	Silence to 20 kHz	31 discrete settings
Level	-60 dBFS to 0 dBFS	1 dB resolution
Preemphasis	None, CD, and FCC	
Click	1 s, 2 s, 3 s, 4 s, and Off	
Timing offset		
Range	Full color frame	
Resolution	< 1/27 MHz	
Output signals		
525-270		
625-270		
ID text	Maximum 20 characters	Blinking interval: Fast, Slow, or OFF
Logo	Gray scale, 4 level	Blinking interval: Fast, Slow, or OFF

Table 1-4: AES/EBU audio outputs

Characteristic	Performance requirement	Reference information
Output connector type		
SPG600	75 Ω BNC: 4, XLR: 2	
SPG300	XLR: 2	
Number of outputs		
SPG600	8	1+2, 3+4, 5+6, and 7+8
SPG300	4	1+2 and 3+4
Quantized resolution		20 or 24 bits (user selectable)
Audio parameters		
Frequency	Silence to 20 kHz	31 discrete settings
Level	-60 dBFS to 0 dBFS	1 dB resolution
Preemphasis	None, CD, and FCC	
Click	1 s, 2 s, 3 s, 4 s, and Off	
Output level	1 V \pm 0.1 V 5 V \pm 0.3 V	Terminated 75 Ω , unbalanced to BNC Terminated 110 Ω , balanced to XLR
Required receiver termination	75 Ω \pm 10% for unbalanced to BNC 110 Ω \pm 10% for balanced to XLR	
Rise and fall time	30 ns to 44 ns 5 ns to 30 ns	10% to 90% to BNC 10% to 90% to XLR
Jitter	\pm 8 ns	
Timing offset		
Range	160 ms	
Resolution	1 μ s	
Word clock		
Connector	BNC	
Frequency	48 kHz	
Level	CMOS compatible	
Impedance	75 Ω \pm 10%	

Table 1-5: Analog audio outputs

Characteristic	Performance requirement	Reference information
Output connector type	XLR	
Number of channels	2	1+2/RIGHT and 3+4/LEFT
Output impedance	12 Ω	
Audio parameters		
Frequency	Silence to 20 kHz	31 discrete settings
Level	-48 dBu to 12 dBu	1 dB resolution
Click	1 s, 2 s, 3 s, 4 s, and Off	

Table 1-6: GPI (general purpose interface)

Characteristic	Performance requirement	Reference information
Output connector type		D-sub, 9 pin
Outputs	Pin 1: Error output (go to low when an error occurs) Pin 9: GND	
Output level	< 0.4 V	Measured at 100 mA sink or maximum 4 Ω
Inputs	Pin 3: Input 1 Pin 4: Input 2 Pin 5: Input 3 Pin 6: GND	Active low input
Input level	TTL compatible	Inputs are pulled up with 10 k Ω

Table 1-7: SNMP error report

Characteristic	Performance requirement	Reference information
Protocol		SNMP v1, v2c
Alarm		The same alarm as the GPI will be reported.
Status		Serial number, firmware and hardware version, hardware configuration/option, etc.

Table 1-8: AC power source

Characteristic	Performance requirement	Reference information
Rating voltage		100 V to 240 V, 50/60 Hz
Voltage range		90 V to 250 V, 50/60 Hz
Power consumption		SPG600: 85 VA, 35 W SPG300: 65 VA, 30 W
Surge current		< 20 A: SPG600 and SPG300

Table 1-9: Clearance

Characteristic	Performance requirement	Reference information
Side		5 cm (2 in)
Rear		7.5 cm (3 in)

Table 1-10: Mechanical characteristics

Characteristic	Description
SPG600	
Dimensions	See Figure 1-1.
Height	43.6 mm (1.7 in)
Width	482.5 mm (19.0 in)
Depth	557.5 mm (21.9 in)
Net weight	Approximately 6 kg (with rack rail)
SPG300	
Dimensions	See Figure 1-2.
Height	43.6 mm (1.7 in)
Width	206.2 mm (8.1 in)
Depth	435.7 mm (17.2 in)
Net weight	Approximately 2.5 kg

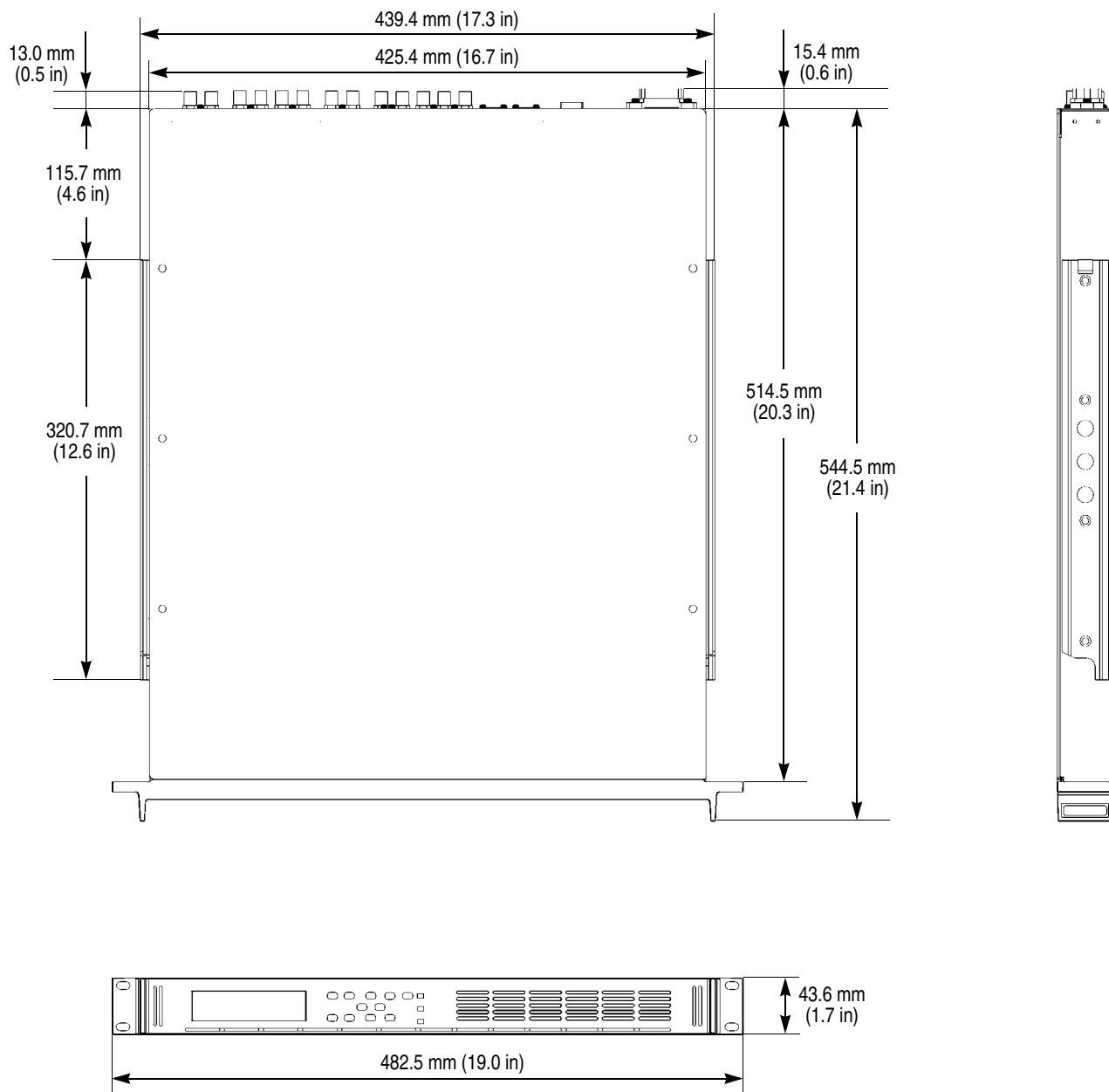

Figure 1-1: SPG600 dimensions

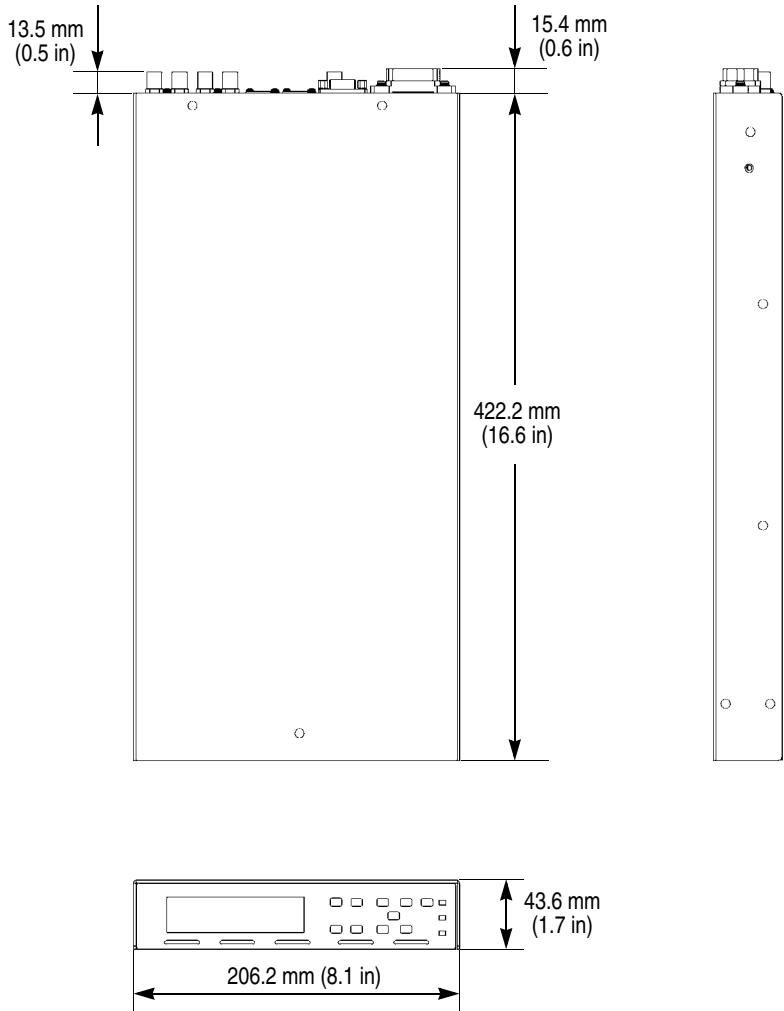

Figure 1-2: SPG300 dimensions

Table 1-11: Environmental characteristics

Characteristic	Description
Temperature	
Operating	0 °C to +40 °C
Nonoperating	-20 °C to +60 °C
Relative humidity	
Operating	20% to 80% relative humidity (% RH) at up to +40 °C, noncondensing.
Nonoperating	5% to 90% relative humidity (% RH) at up to +60 °C, noncondensing.
Attitude	
Operating	To 3,000 m (10,061 feet)
Nonoperating	To 12,192 m (40,000 feet)
Vibration	
Operating	2.65 m/s ² (0.27 Grms), 5 Hz to 500 Hz, 10 minutes per axis, three axes.
Nonoperating	22.3 m/s ² (2.28 Grms), 5 Hz to 500 Hz, 10 minutes per axis, three axes.
Shock	
Nonoperating	294 m/s ² (30 G), half-sine, 11 ms duration.

Certifications and Compliances

Table 1-12: Certifications and compliances

Category	Standards or description
EC Declaration of Conformity-EMC	<p>Meets the intent of Directive 89/336/EEC for Electromagnetic Compatibility. Compliance was demonstrated to the following specifications as listed in the Official Journal of the European Communities:</p> <p>EN55103 Product family standard for audio, video, audio-visual and entertainment lighting control apparatus for professional use.</p> <p> Environmental E2-commercial and light industrial</p> <p> Part 1 Emission</p> <p> EN55022 Class B radiated and conducted emissions</p> <p> EN55103-1, Annex A Radiated magnetic field emissions</p> <p> EN55103-1, Annex B Inrush current; I peak=14.6 amps</p> <p> Part 2 Immunity</p> <p> IEC61000-4-2 Electrostatic discharge immunity</p> <p> IEC61000-4-3 RF electromagnetic field immunity</p> <p> IEC61000-4-4 Electrical fast transient/burst immunity</p> <p> IEC61000-4-5 Power line surge immunity</p> <p> IEC61000-4-6 Conducted RF immunity</p> <p> IEC61000-4-11 Voltage dips and interruptions immunity</p> <p> EN55103-2, Annex A Radiated magnetic field immunity</p> <p>EN61000-3-2 AC power line harmonic current emissions</p> <p>EN61000-3-3 Voltage changes, fluctuations, & flicker</p>
EC-Declaration of Conformity-Safety	<p>Compliance was demonstrated to the following specification as listed in the Official Journal of the European Union:</p> <p>EN61010-1:2001 Safety requirements for electrical equipment for measurement, control, and laboratory use.</p>
Australia/New Zealand Declaration of Conformity-EMC	<p>Complies with the EMC Framework, demonstrated per Emission Standard AS/NZS 2064 (Industrial, Scientific, and Medical Equipment).</p>
Safety	<p>Complies with the following safety standards:</p> <p>UL 61010B-1</p> <p>CAN/CSA C22.2 No. 1010.1</p> <p>IEC 61010 -1:2001 Second Edition</p>
Installation (overvoltage) Category	<p>Terminals on this product may have different installation (overvoltage) category designations. The installation categories are:</p> <p>CAT III Distribution-level mains (usually permanently connected). Equipment at this level is typically in a fixed industrial location.</p> <p>CAT II Local-level mains (wall sockets). Equipment at this level includes appliances, portable tools, and similar products. Equipment is usually cord-connected.</p> <p>CAT I Secondary (signal level) or battery operated circuits of electronic equipment.</p>

Table 1-12: Certifications and compliances (cont.)

Category	Standards or description
Pollution Degree Descriptions	<p>A measure of the contaminants that could occur in the environment around and within a product. Typically the internal environment inside a product is considered to be the same as the external. Products should be used only in the environment for which they are rated.</p> <p>Pollution Degree 1 No pollution or only dry, nonconductive pollution occurs. Products in this category are generally encapsulated, hermetically sealed, or located in clean rooms.</p> <p>Pollution Degree 2 Normally only dry, nonconductive pollution occurs. Occasionally a temporary conductivity that is caused by condensation must be expected. This location is a typical office/home environment. Temporary condensation occurs only when the product is out of service.</p> <p>Pollution Degree 3 Conductive pollution, or dry nonconductive pollution that becomes conductive due to condensation. These are sheltered locations where neither temperature nor humidity is controlled. The area is protected from direct sunshine, rain, or direct wind.</p>
Pollution Degree	Pollution Degree 2 (as defined IEC 61010-1)
Equipment Type	Test and measuring
Overvoltage Category	Overvoltage Category II (as defined in IEC 61010-1)
Safety Class	Safety Class I (as defined in IEC 61010-1)-ground product
Temperature	5 °C to 40 °C



Operating Information

Installation

This section contains the following topics:

- Supplying operating power
- Operating environment
- Applying and interrupting power
- Repackaging instructions

Supplying Operating Power

NOTE. Read all information and heed all warnings in this subsection before connecting the sync pulse generator to a power source.



WARNING. AC POWER SOURCE AND CONNECTION. The sync pulse generator operates from a single-phase power source. It has a three-wire power cord and two-pole, three-terminal grounding type plug. The voltage to ground (earth) from either pole of the power source must not exceed the maximum rated operating voltage, 250 volts.

Before making connection to power source, be sure the sync pulse generator has a suitable two-pole, three-terminal grounding-type plug.

GROUNDING. This instrument is safety Class 1 equipment (IEC designation). All accessible conductive parts are directly connected through the grounding conductor of the power cord to the grounded (earthing) contact of the power plug.



WARNING. *The power input plug must be inserted only in a mating receptacle with a grounding contact where earth ground has been verified by a qualified service person. Do not defeat the grounding connection. Any interruption of the grounding connection can create an electric shock hazard.*

For electric shock protection, the grounding connection must be made before making connection to the instrument's input or output terminals.

Power Cord Information

A power cord with the appropriate plug configuration is supplied with each sync pulse generator. Table 2-1 gives the color-coding of the conductors in the power cord. If you require a power cord other than the one supplied, refer to Table 2-2, Power cord identification.

Table 2-1: Power-cord conductor identification

Conductor	Color	Alternate color
Ungrounded (Line)	Brown	Black
Grounded (Neutral)	Light Blue	White
Grounded (Earthing)	Green/Yellow	Green

Table 2-2: Power cord identification

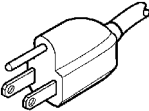
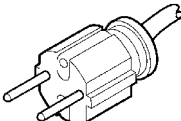
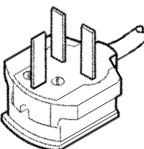
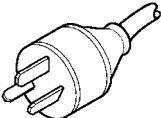
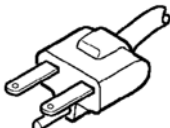
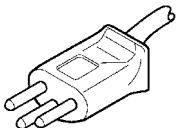
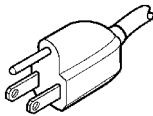
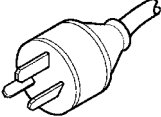
Plug configuration	Normal usage	Option number
	North America 115 V	Standard (A0)
	Universal Euro 220 V	A1
	United Kingdom 240 V	A2
	Australia 240 V	A3
	North America 250 V	A4
	Switzerland 240V	A5
	Japan 100 V	A6
	China 240 V	A10
	No power code supplied.	A99

Operating Voltage

The sync pulse generator operates with any line voltage from 90-250 VAC_{RMS} with line frequency 50 or 60 Hz. Before plugging the cord into the outlet, be sure that the line voltage is in the proper range.

Operating Environment

The following environment requirements are provided to ensure proper operation and long instrument life.

Operating Temperature Operate the sync pulse generator where the ambient air temperature is from 0 °C to +40 °C. Store the sync pulse generator in ambient temperatures from -20 °C to +60 °C. After storage at temperatures outside the operating limits, allow the chassis to stabilize at a safe operating temperature before applying power.

Ventilation Requirements Leave space for cooling by ensuring standard side clearance for rack mounting or 2 inches (5.1 cm) of side clearance for countertop use. Also, ensure sufficient rear clearance (approximately 3 inches) so that cables are not damaged by sharp bends.

Applying and Interrupting Power

Consider the following information when you power on or power off the sync pulse generator, or when external power loss occurs.

Connect the Power Cable Connect the power cable to the instrument first, and then connect it to the AC power source. Note that connecting the power cable causes the instrument to power on. Refer to Table 2-2 for power cord identification.



CAUTION. *The instrument does not have a power switch. When you connect the power cable to AC line connector, the instrument powers on.*

After connecting the power, make sure that the fan inside the instrument is working. If the fan is not working, turn off the power by disconnecting the power cable from the AC power source and contact your local Tektronix Field Office or representative.

Power Off To power off the sync pulse generator, disconnect the power cable from the AC power source.

Repackaging Instructions

When you ship this instrument, use the original packaging material if possible. If the original packaging is unfit for use or is not available, repackage the instrument using the following procedure:

1. Obtain a corrugated cardboard shipping carton having inside dimensions at least six inches greater than the instrument dimensions and having a carton test strength of at least 125 kg (275 pounds).
2. If the instrument is being shipped to a Tektronix Service Center for repair or calibration, attach a tag to the instrument showing the following information:
 - The owner of the instrument (with address).
 - The name of a person at your company who may be contacted if additional information is needed.
 - The complete instrument type and serial number.
 - A description of the service required.
3. Wrap the instrument with polyethylene sheeting or equivalent to protect the outside finish and prevent entry of packing materials into the instrument.
4. Cushion the instrument on all sides by tightly packing dunnage or urethane foam between the carton and the instrument, allowing for three inches (7.62 cm) of padding on each side (including top and bottom).
5. Seal the carton with shipping tape or with an industrial stapler.
6. Mark the carton with the address of the Tektronix Service Center and your return address in one or more prominent locations.

Installed Options

Your instrument may be equipped with one or more instrument options. Except for the line-cord options described by Table 2-2 on page 2-3, all options are listed and described in Section 7, *Options*. For further information and prices of instrument options, see your Tektronix Products catalog or contact your Tektronix Field Office.

Menus

This section describes all of the available sync pulse generator menus and submenus. The following menus are available from the front-panel menu buttons:

- Video menu
- Audio menu
- Genlock menu
- System menu

Video Menu

Pressing the VIDEO button displays the Video menu. This menu lets you set output signals, timing of the output signals, overlay, and SDI parameters. Use the up (▲) or down (▼) arrow button to scroll through the menu. Figure 2-1 shows the Video menu diagram. Use the left (◀) or right (▶) arrow button to select functions or submenus in each Video menu.

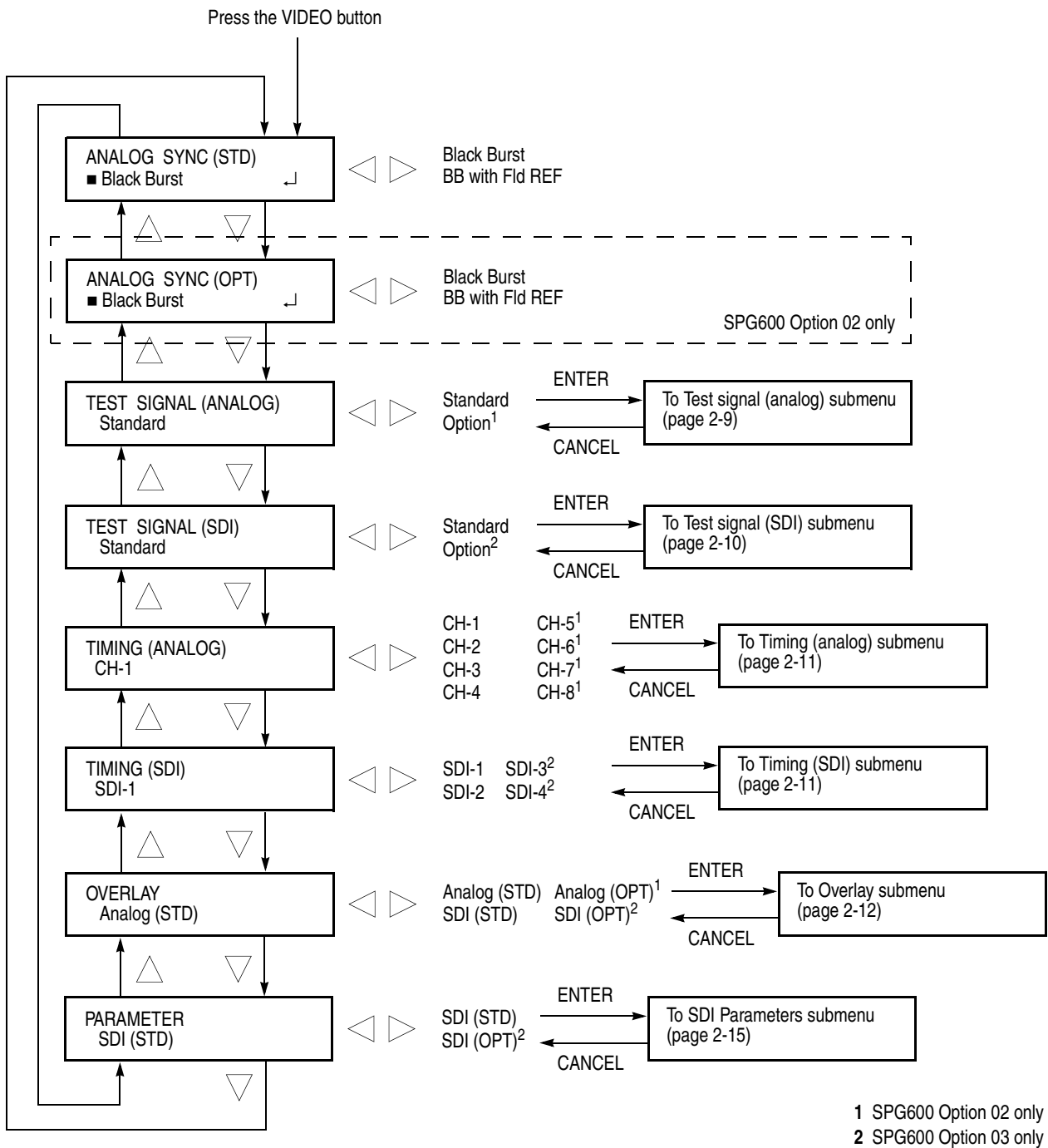

Figure 2-1: Video menu diagram

**Test Signal (Analog)
Submenu**

This menu allows you to select a test signal for analog output(s). Use the up (▲) or down (▼) arrow button to scroll through the menu. Figure 2-2 shows the Test signal (analog) submenu diagram. Use the left (◀) or right (▶) arrow button to select a signal.

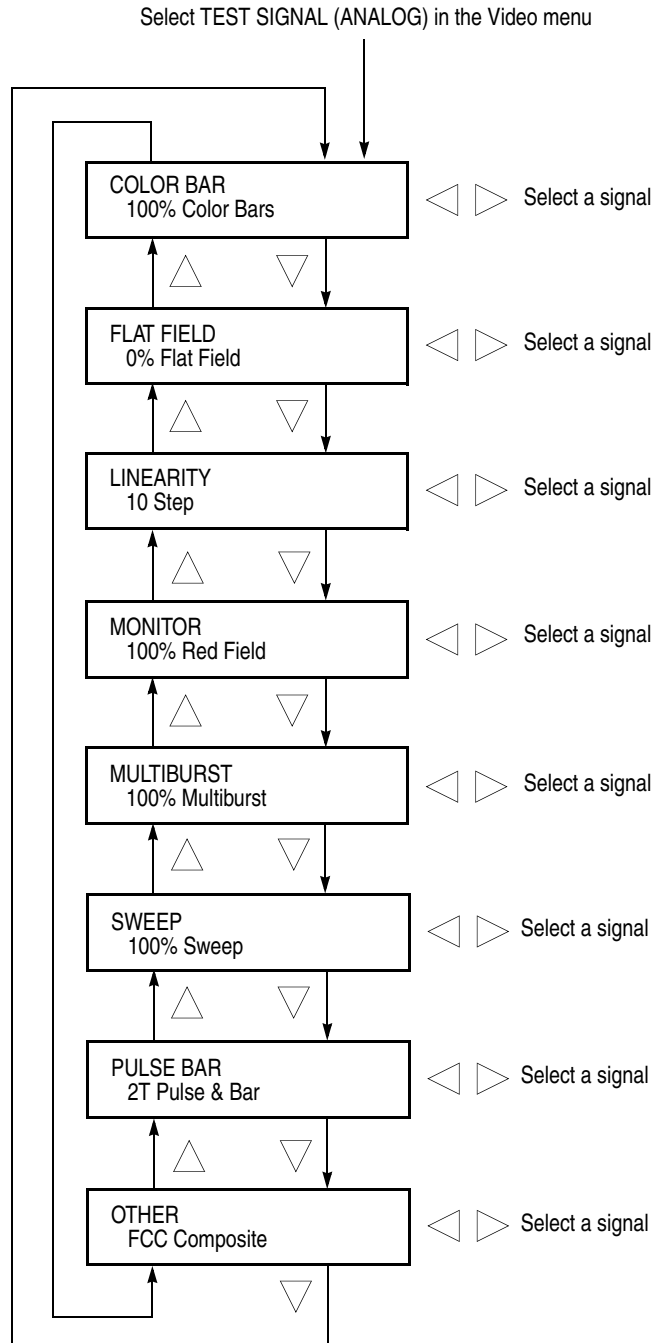

Figure 2-2: Test signal (analog) submenu diagram

Test Signal (SDI) Submenu

This menu allows you to select a serial digital test signal for the SDI 2 output(s). Use the up (▲) or down (▼) arrow button to scroll through the menu. Figure 2-3 shows the Test signal (SDI) submenu diagram. Use the left (◀) or right (▶) arrow button to select a signal.

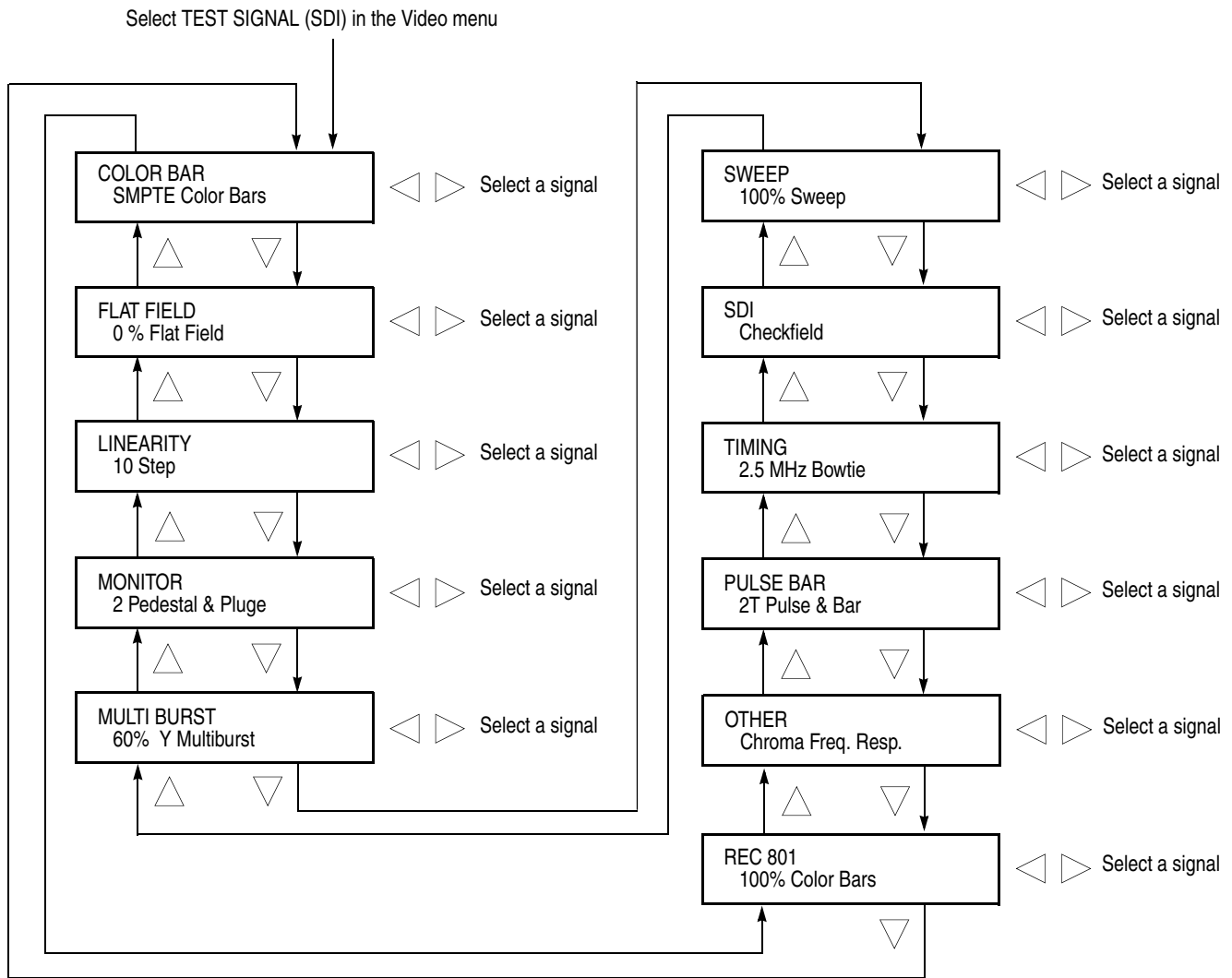

Figure 2-3: Test signal (SDI) submenu diagram

Timing (Analog) Submenu

This menu allows you to adjust the selected analog output timing offset relative to the genlock signal or the internal reference signal. Use the up (▲) or down (▼) arrow button to scroll through the menu. Figure 2-4 shows the Timing (analog) submenu diagram.

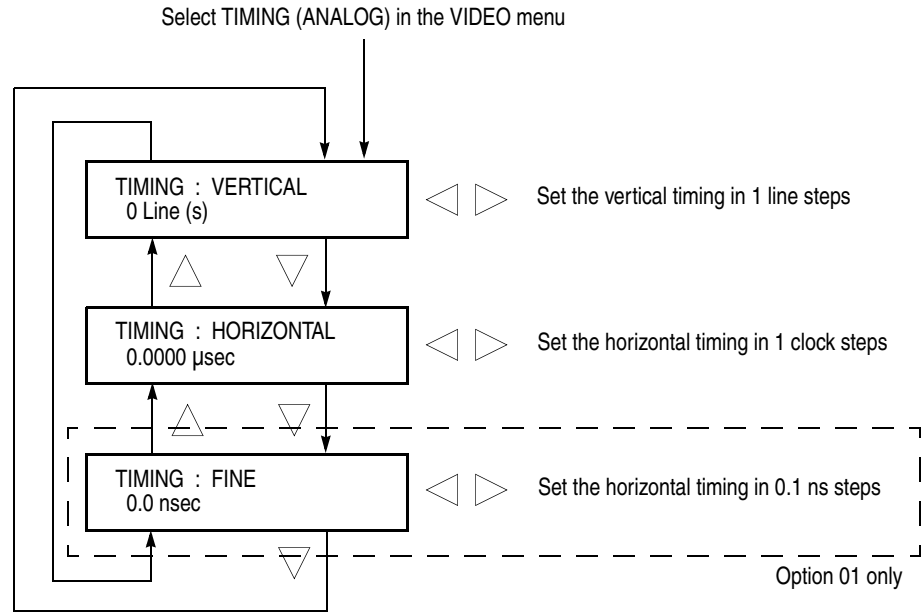

Figure 2-4: Timing (analog) submenu diagram

Timing (SDI) Submenu

This menu allows you to adjust the timing offset of the selected serial digital output relative to the genlock signal or the internal reference signal. Use the up (▲) or down (▼) arrow button to scroll through the menu. Figure 2-5 shows the Timing (SDI) submenu diagram.

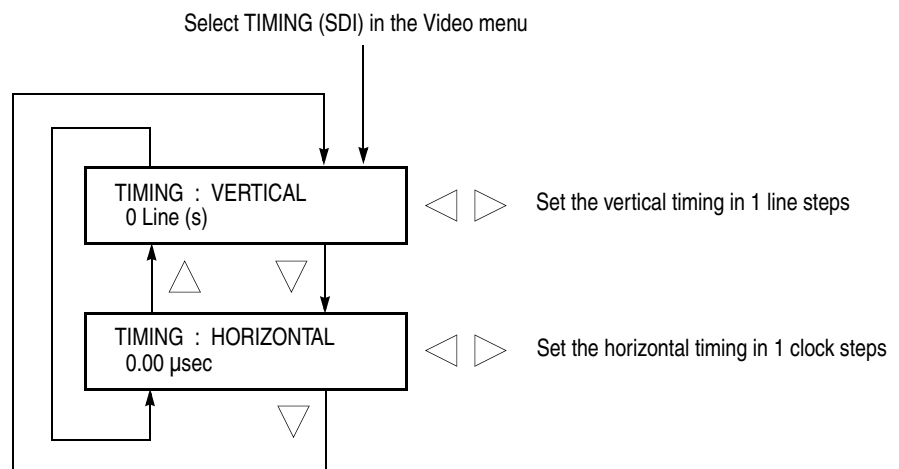

Figure 2-5: Timing (SDI) submenu diagram

Overlay Submenu This menu allows you to select an item (logo or ID text) that is overlaid on the output test signal. Use the up (▲) or down (▼) arrow button to scroll through the menu. Figure 2-6 shows the Overlay submenu diagram.

NOTE. The Overlay submenu contents are common for both analog and serial digital signals except for the menu title on the first line (ANALOG or SDI).

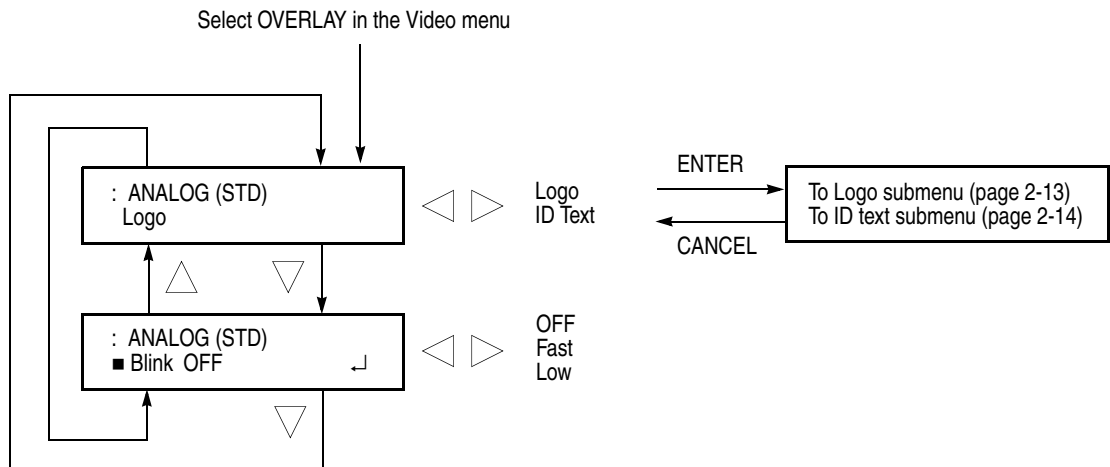

Figure 2-6: Overlay submenu diagram

Logo Submenu

This menu allows you to overlay and position a logo graphic on an output test signal. Use the up (▲) or down (▼) arrow button to scroll through the menu. Figure 2-7 shows the Logo submenu diagram.

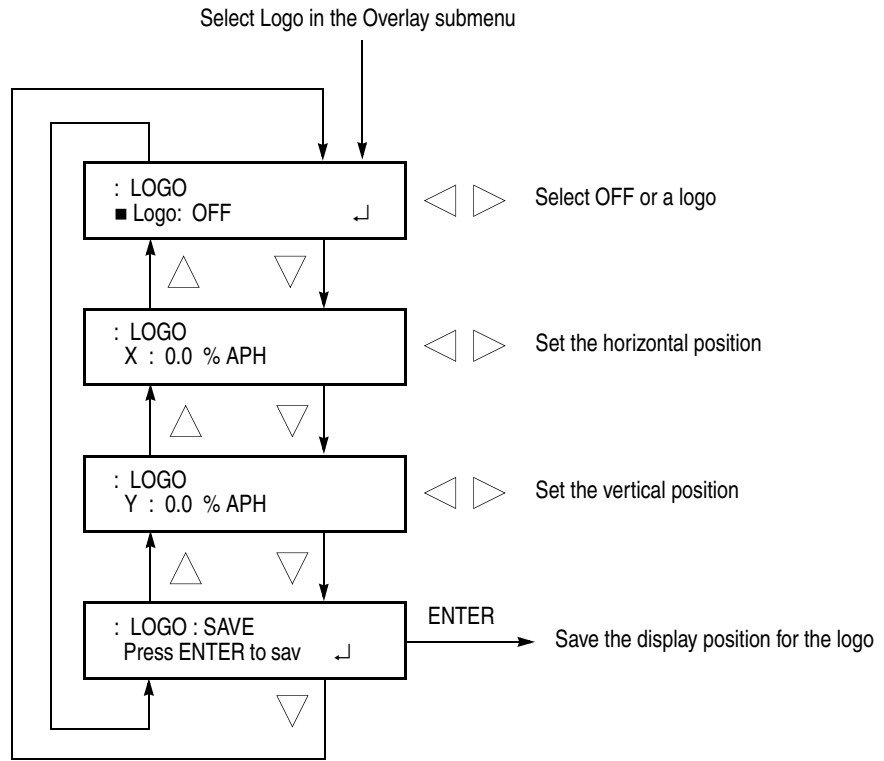

Figure 2-7: Logo submenu diagram

You can create a logo file using the Logo Generator application. Refer to the *SPG600 & SPG300 Sync Pulse Generators User Manual* included on the product CD-ROM for detailed information for using Logo Generator.

ID Text Submenu

This menu allows you to edit and position a text string that is overlaid on the output test signal. Use the up (▲) or down (▼) arrow button to scroll through the menu. Figure 2-8 shows the ID text submenu diagram.

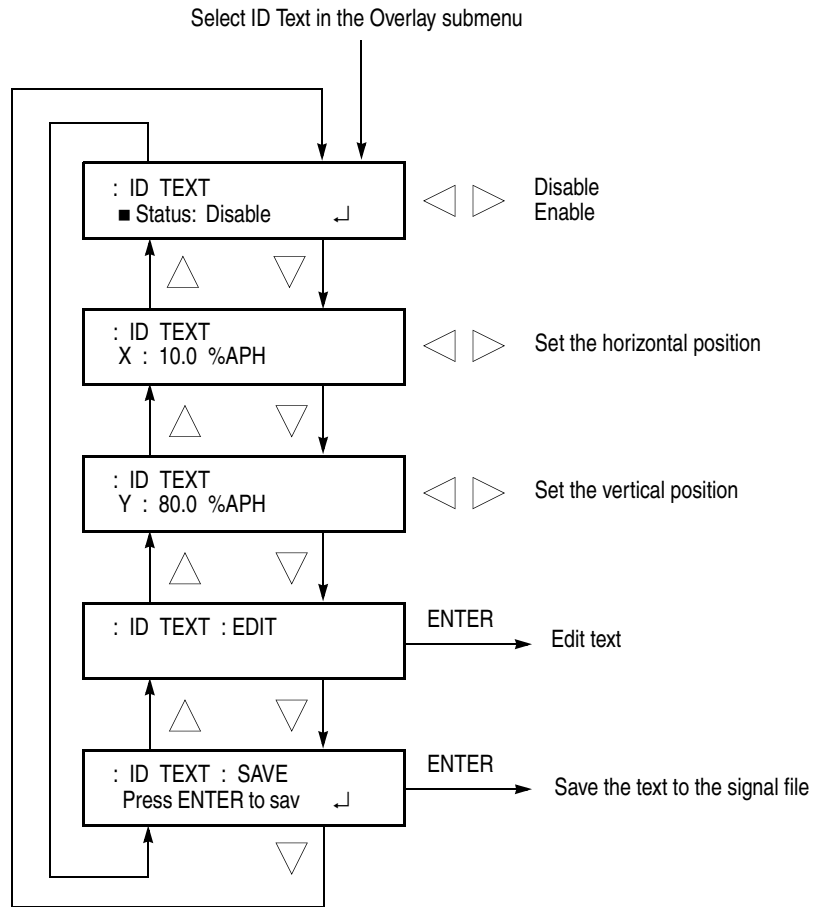

Figure 2-8: ID text submenu diagram

SDI Parameters Submenu

This menu allows you to select which component(s) of the serial digital signal is (are) available, the serial digital signal resolution, and the insertion of the EDH (Error Detection and Handling) bits. Use the up (▲) or down (▼) arrow button to scroll through the menu. Figure 2-9 shows the SDI parameters submenu diagram.

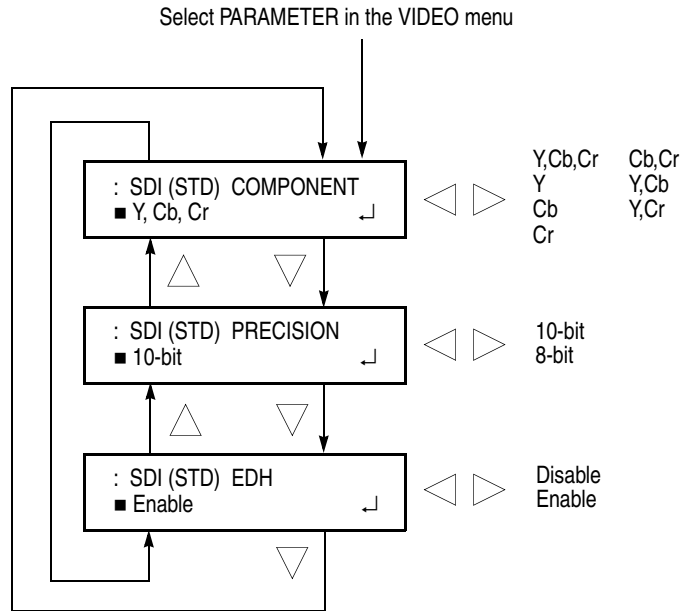

Figure 2-9: SDI parameters submenu

Audio Menu

Pressing the AUDIO button displays the Audio menu. This menu lets you set the parameters of the AES/EBU audio and embedded audio in the serial digital signal. Use the up (▲) or down (▼) arrow button to scroll through the menu. Figure 2-10 shows the Audio menu.

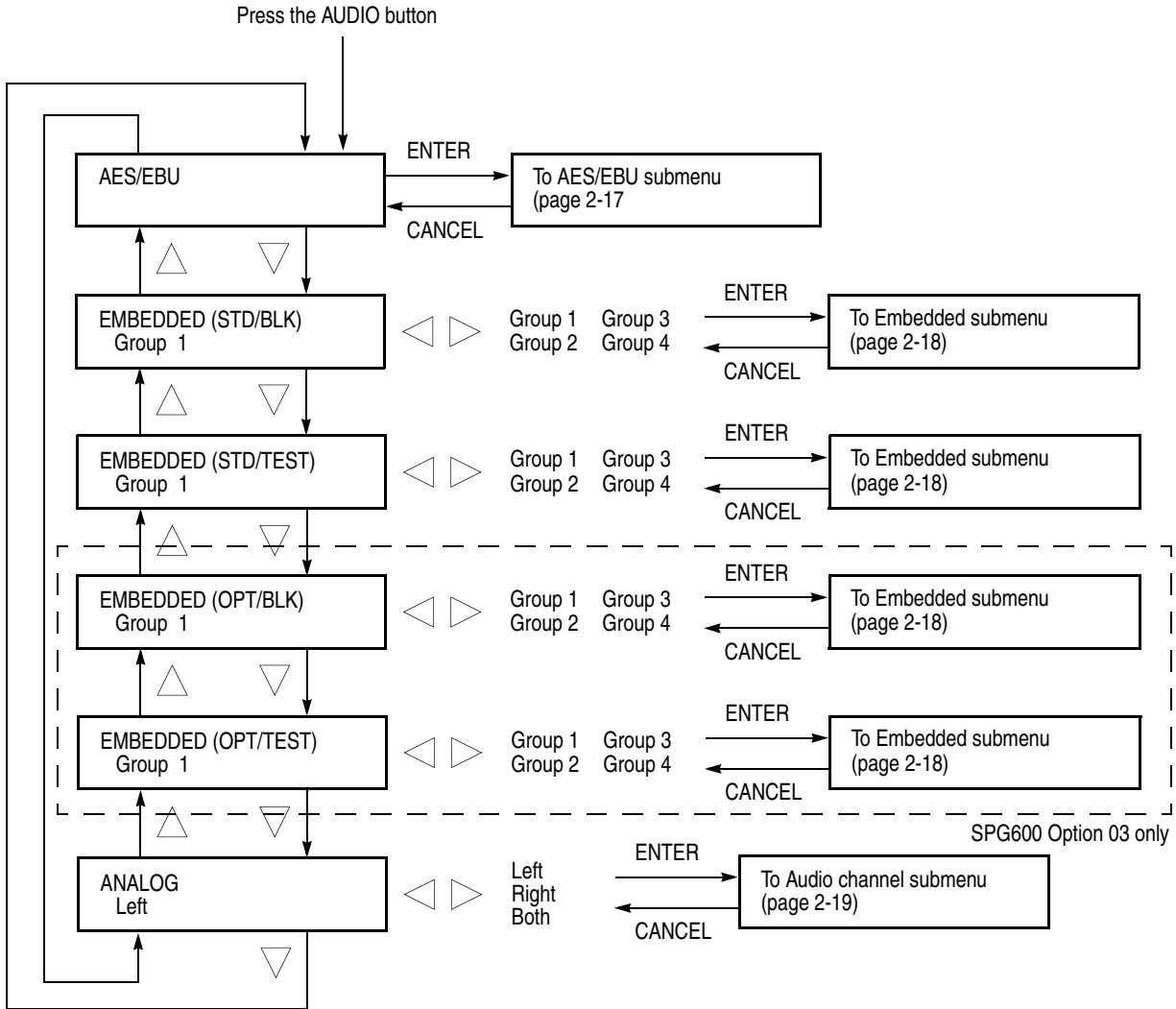

Figure 2-10: Audio menu diagram

NOTE. The ANALOG menu item is only available when you select Analog Audio in the CONFIGURATION: XLR OUTPUT menu.

AES/EBU Submenu

This menu allows you to select an audio channel, the state of the audio emphasis bits, the resolution of the serial digital audio signal data, and the audio timing. Use the up (▲) or down (▼) arrow button to scroll through the menu. Figure 2-11 shows the AES/EBU submenu diagram.

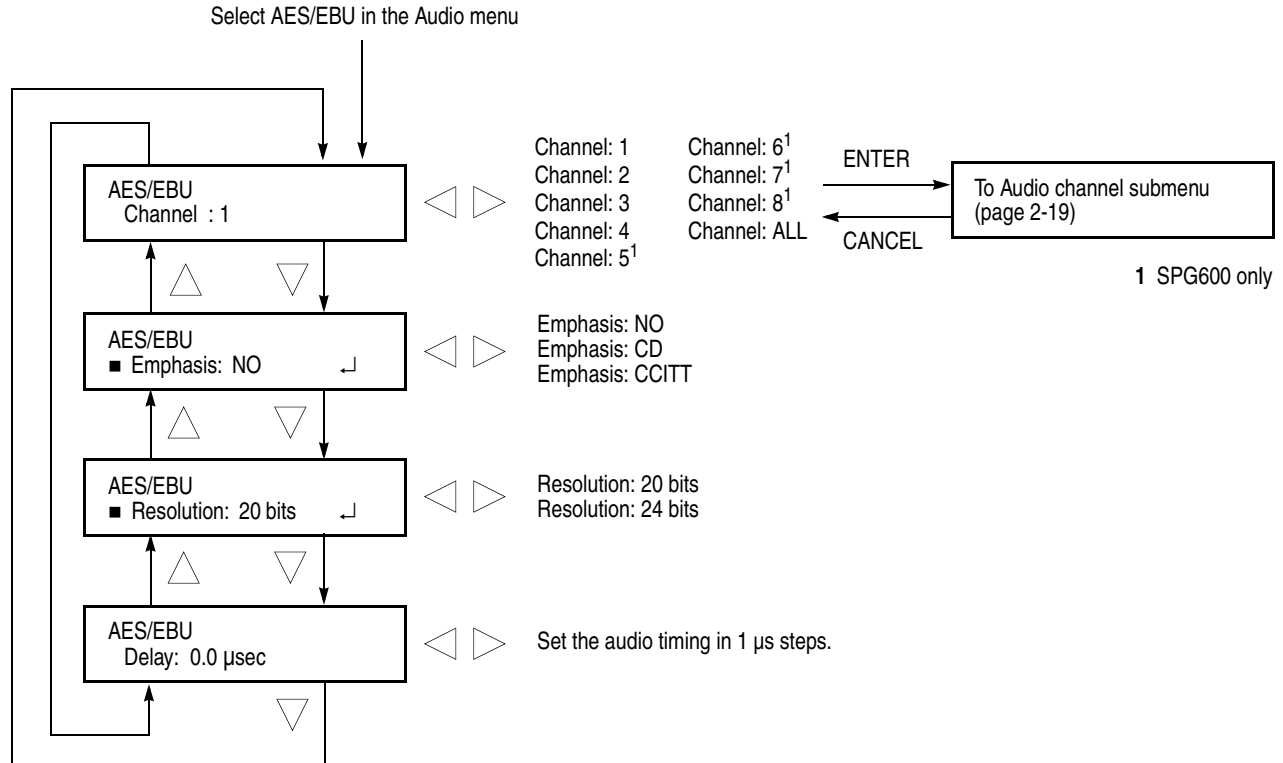

Figure 2-11: AES/EBU submenu diagram

Embedded Submenu

This menu allows you to enable or disable the generation of embedded audio, select an audio channel, set the state of the audio emphasis bits, and set the resolution of the serial digital audio signal data. Use the up (▲) or down (▼) arrow button to scroll through the menu. Figure 2-12 shows the Embedded submenu diagram.

NOTE. The Embedded submenu contents are common for the serial digital black signals and the serial digital test signals except for the menu title on the first line.

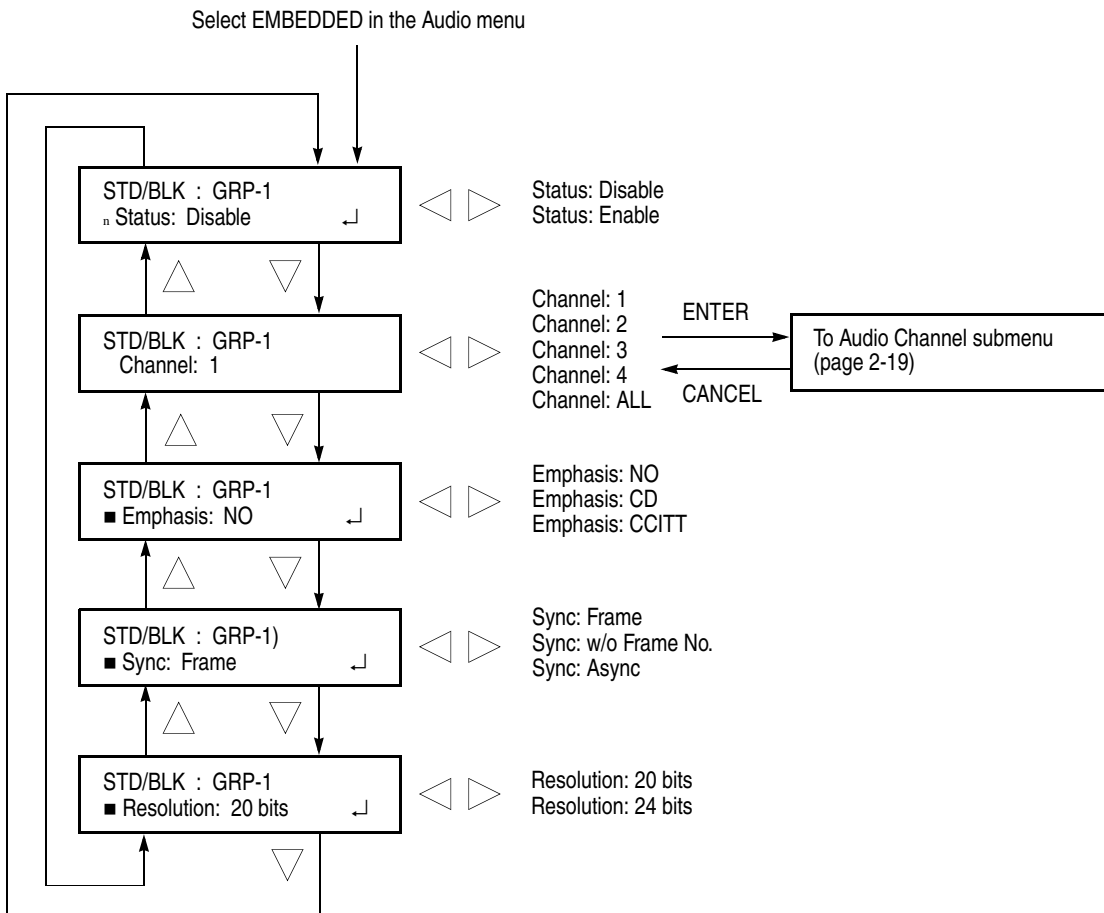

Figure 2-12: Embedded submenu diagram

Audio Channel Submenu

This menu allows you to set the frequency, amplitude, and audio click of the selected audio channel. Use the up (▲) or down (▼) arrow button to scroll through the menu items. Figure 2-13 shows the Audio channel submenu diagram.

NOTE. The Audio channel submenu contents are common for AES/EBU audio, Embedded audio, and Analog audio except for the menu title in the first line and some parameter settings.

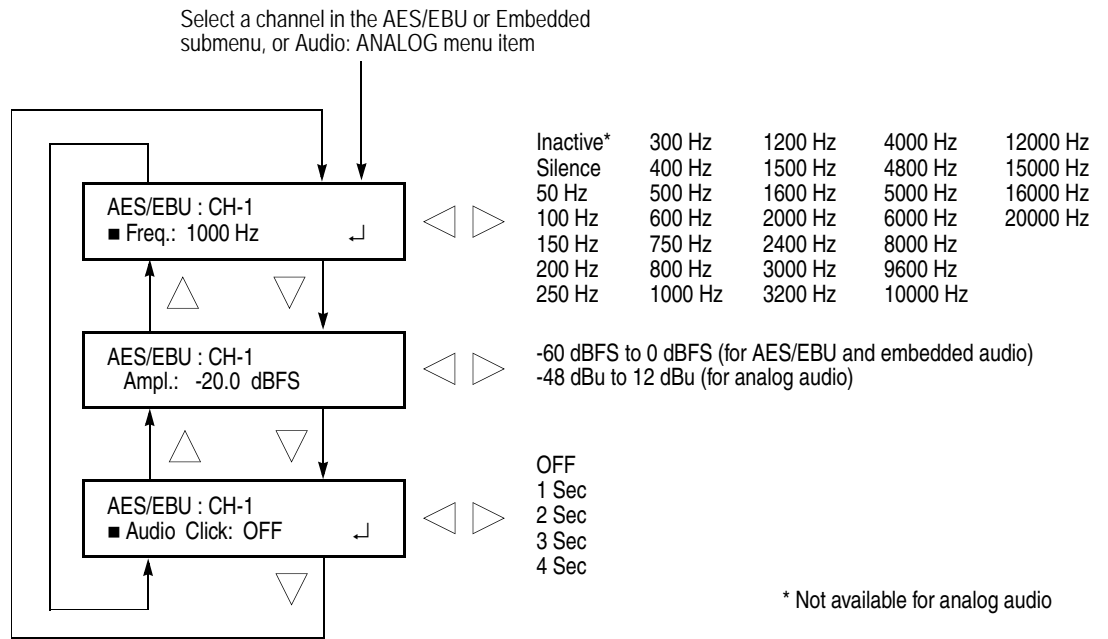

Figure 2-13: Audio channel submenu diagram

Genlock Menu

Pressing the GENLOCK button displays the Genlock menu. This menu lets you select the genlock source, set the timing offset, and set the instrument actions when lock is lost. Use the up (▲) or down (▼) arrow button to scroll through the menu. Figure 2-14 shows the Genlock menu diagram.

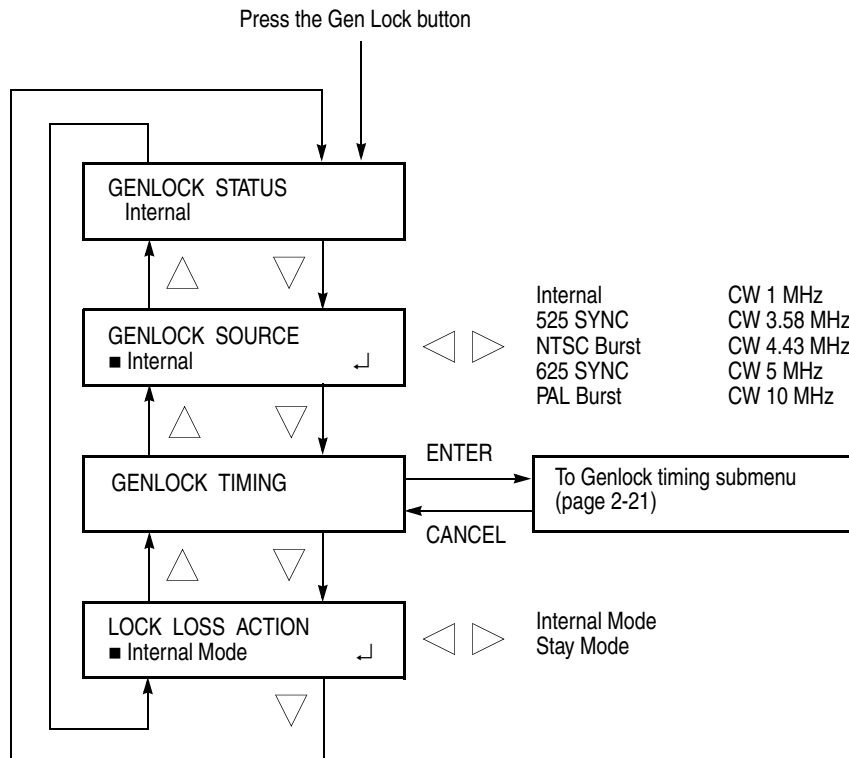

Figure 2-14: Genlock menu diagram

Genlock Timing Submenu

This menu allows you to adjust the timing offset of the input signal relative to the internal reference signal (frame reset signal). Use the up (▲) or down (▼) arrow button to scroll through the menu. Figure 2-15 shows the Genlock timing submenu diagram.

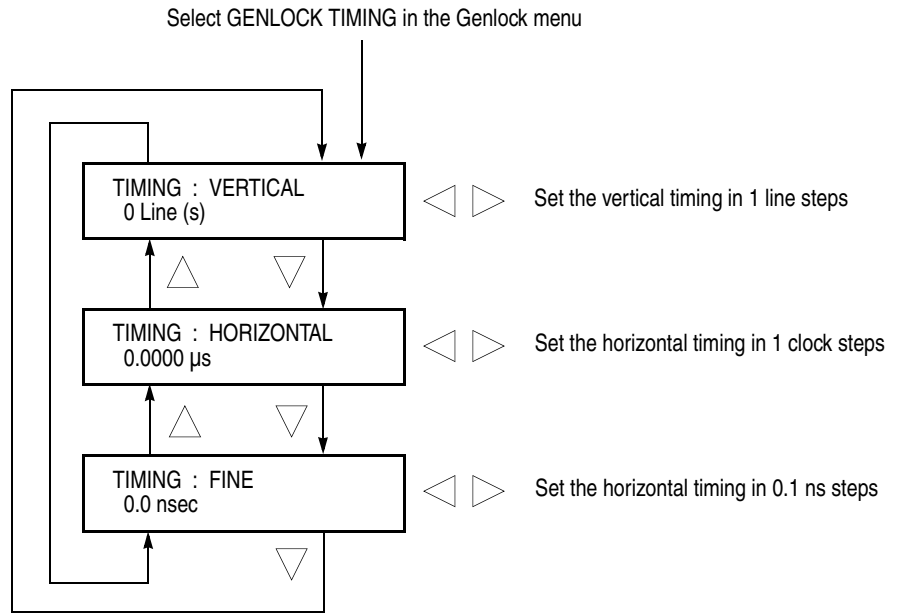

Figure 2-15: Genlock timing submenu diagram

System Menu

Pressing the **SYSTEM** button displays the System menu. This menu lets you set the system-related settings such as network parameters and output configuration. Use the up (▲) or down (▼) arrow button to scroll through the menu. Figure 2-16 shows the System menu diagram.

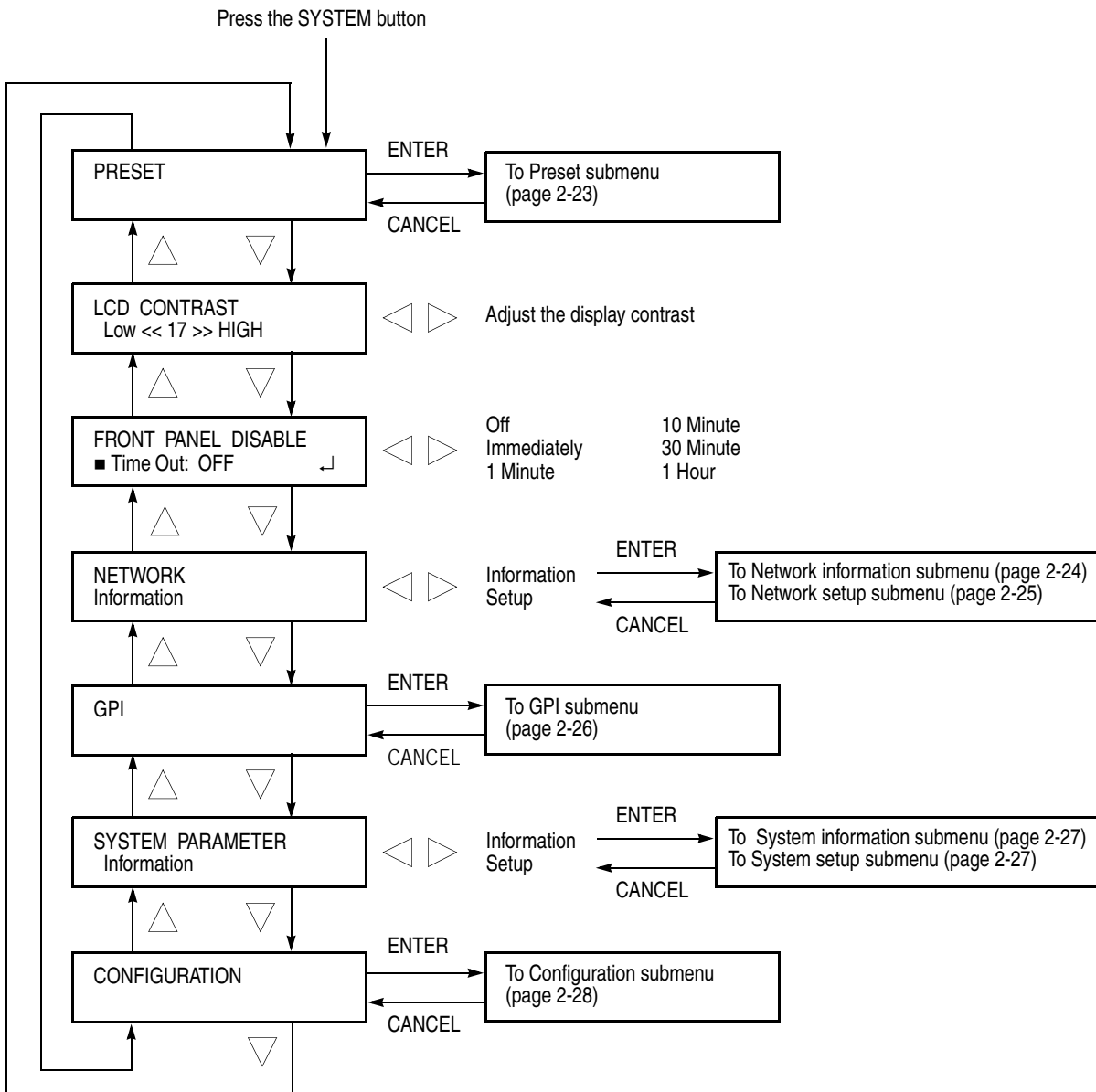

Figure 2-16: System menu diagram

Preset Submenu This menu allows you to store and recall instrument configuration settings. Use the up (▲) or down (▼) arrow button to scroll through the menu items. Figure 2-17 shows the Preset submenu diagram.

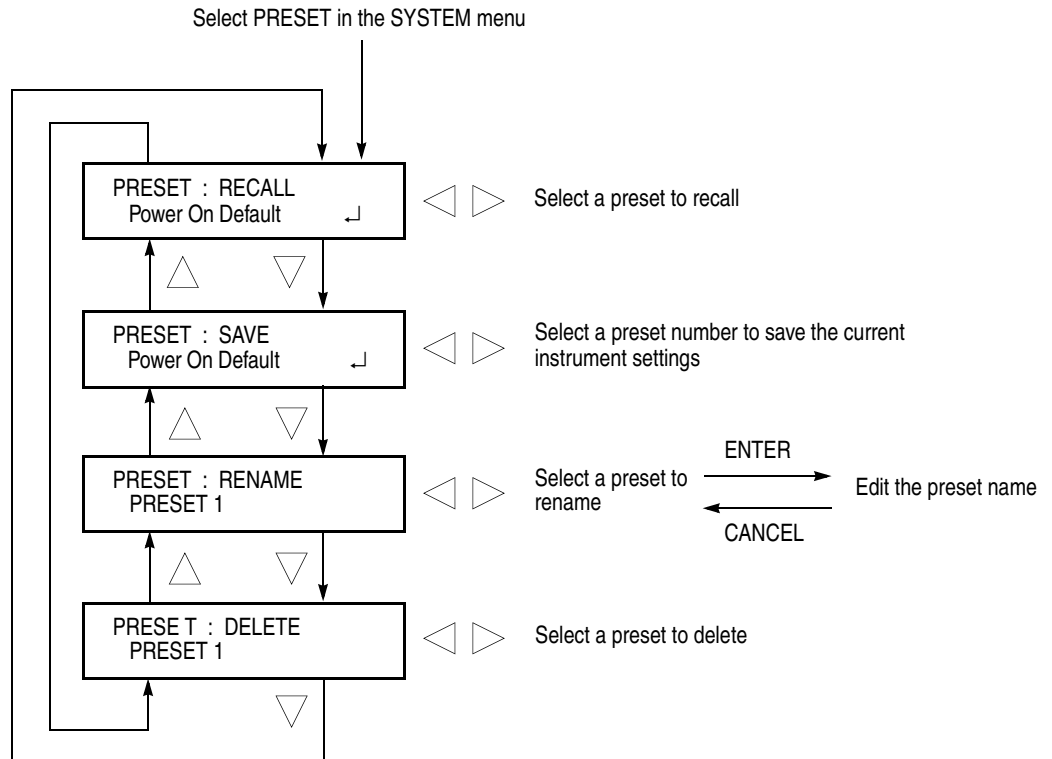

Figure 2-17: Preset submenu diagram

Network Information Submenu

This menu allows you to display all of the current network parameters. Use the up (▲) or down (▼) arrow button to scroll through the menu. Figure 2-18 shows Network information submenu diagram.

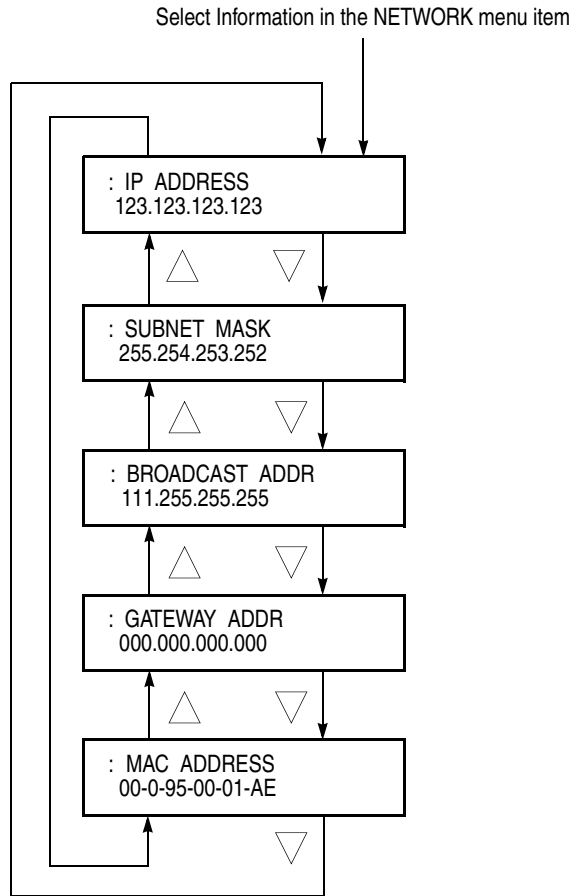

Figure 2-18: Network information submenu diagram

Network Setup Submenu

This menu allows you to set the sync pulse generator network parameters when connecting to a 100BASE-T Ethernet. Use the up (▲) or down (▼) arrow button to scroll through the menu items. Figure 2-19 shows the Network setup submenu diagram.

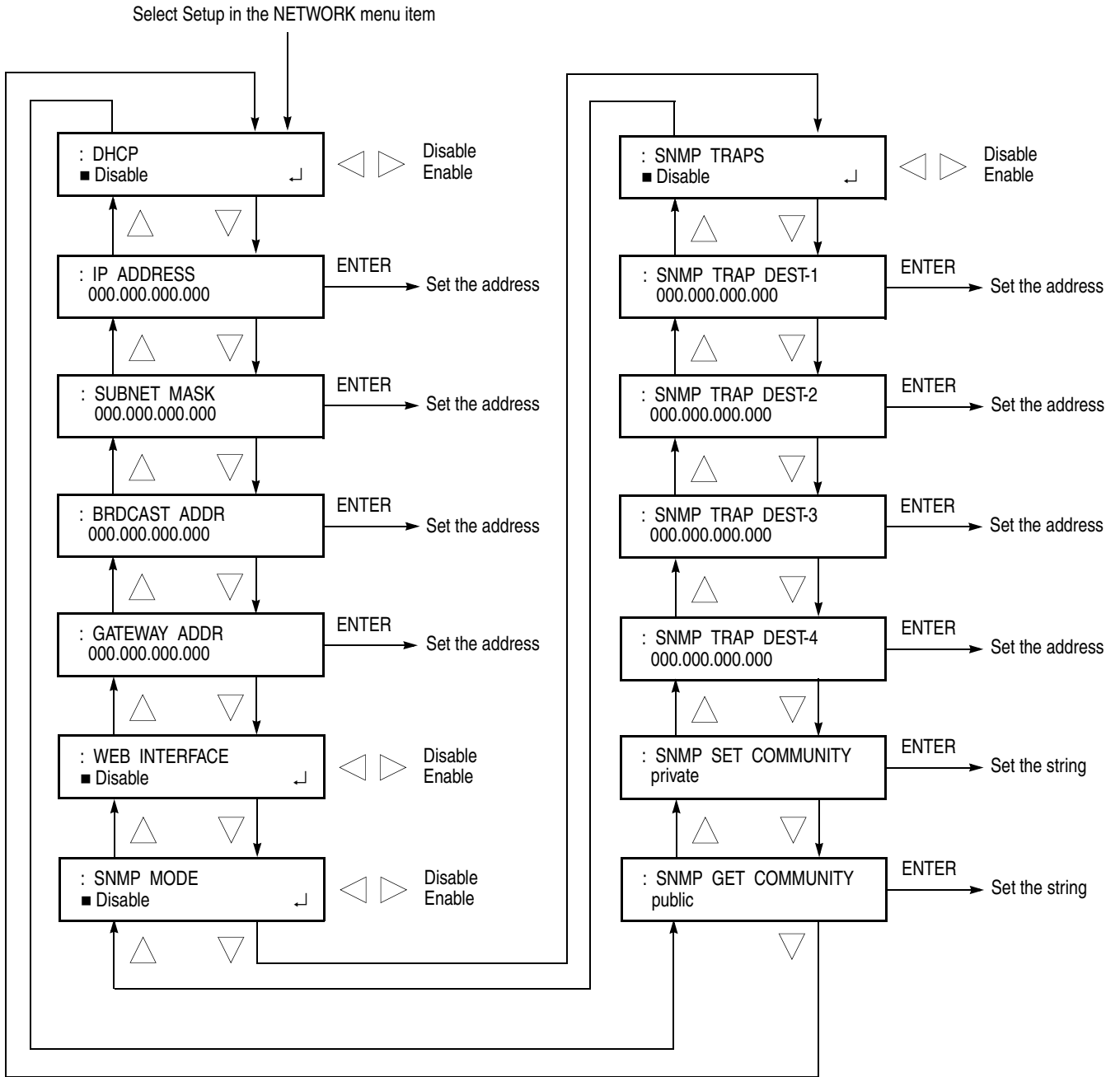

Figure 2-19: Network setup submenu diagram

GPI Submenu This menu allows you to enable or disable the alarm signal output, reset alarm signal output, and display the alarm status. Use the up (▲) or down (▼) arrow button to scroll through the menu. Figure 2-20 shows the GPI submenu diagram.

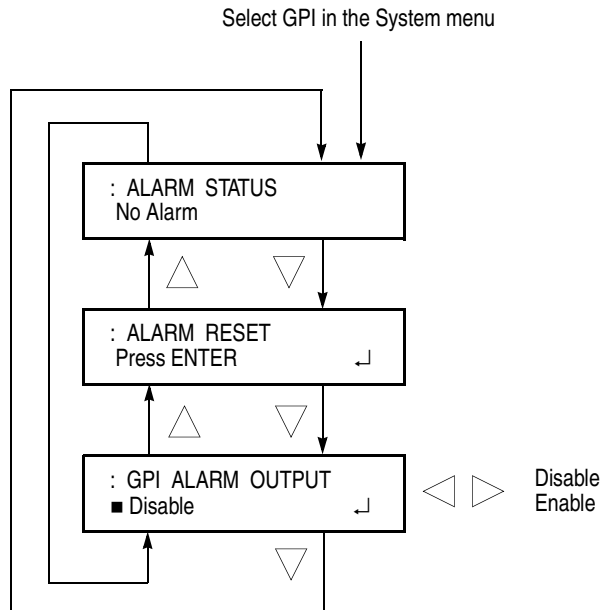

Figure 2-20: GPI submenu diagram

System Information Submenu

This menu allows you to display the system information. Use the up (▲) or down (▼) arrow button to scroll through the menu. Figure 2-21 shows the System information submenu diagram.

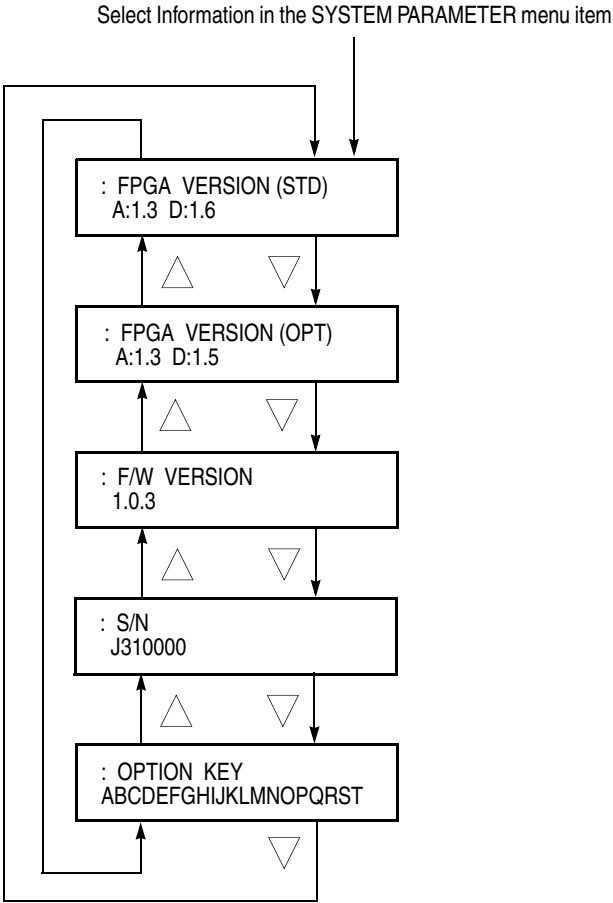

Figure 2-21: System information submenu diagram

System Setup Submenu

This menu allows you to enter the option key that enables the fine timing adjustment feature (Option 01). Figure 2-22 shows the System setup submenu diagram.

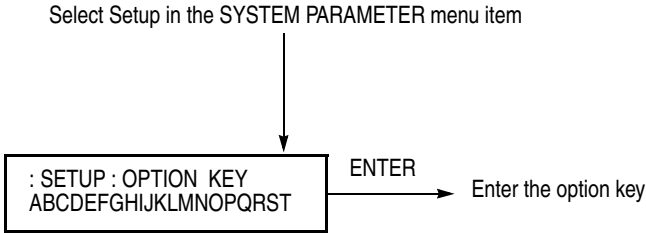

Figure 2-22: System setup submenu diagram

Configuration Submenu

This menu allows you to select the video standard for the output signals and configure the output connectors. Use the up (▲) or down (▼) arrow button to scroll through the menu. Figure 2-23 shows the Configuration submenu diagram.

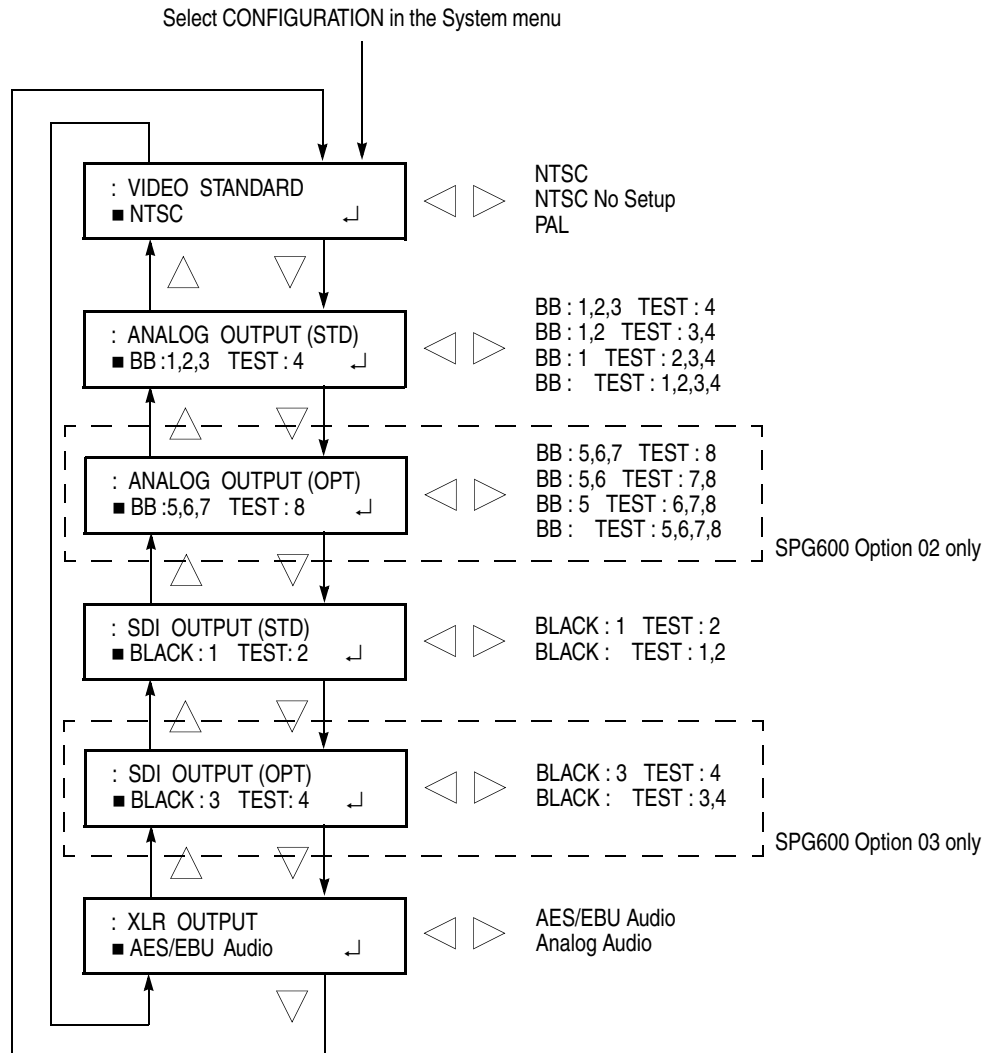

Figure 2-23: Configuration submenu diagram



Theory of Operation

Theory of Operation

This section describes the basic operation of the major circuit blocks or modules in the sync pulse generator. The Diagram section, beginning on page 9-1, includes block diagrams and interconnect diagrams.

A10 Main Board (SPG600) and A50 Main Board (SPG300)

The A10/A50 Main board consists of the following blocks:

Master Clock Oscillator	This block generates a master clock signal. It is generated from the 13.5 MHz OCXO with high accuracy. The frequency is controlled by a 16-bit D/A converter.
Audio Clock	This block generates a 12.7 MHz clock for AES/EBU audio. The clock is phase locked to 13.5 MHz master oscillator.
Video Clock	This block generates a 27 MHz clock for video signals. The clock is phase locked to the 13.5 MHz master clock.
Frame Reset	This block generates a 15/1.001 Hz frame reset signal for the NTSC standard and a 6.25 Hz frame reset signal for the PAL standard.
D/A Converter	The 16-bit D/A converter controls the master clock oscillator frequency.
CPU	The CPU manages all functions in the sync pulse generator.
Flash Memory and SDRAM	This block consists of an 8 MB flash memory and a 16 MB SDRAM. The flash memory holds the data for system boot (1 MB) and the program code (7 MB).
Parallel to Serial Converter	This block converts the CPU parallel bus to the original serial bus.
GPI Interface	This block controls the general purpose interface. The interface is used to recall a preset and output an alarm signal.
Network Interface	This block controls the Ethernet interface for Web and SNMP application. The sync pulse generator has a 100 BASE-T connector on the rear panel.
DC/DC Converter	This block converts the +5 V power, supplied by the Power Supply Module, to -5 V, 3.3 V, 8 V, and 12 V.

Analog Genlock

The analog genlock consists of the following blocks:

Genlock Controller. This block controls the A/D converter, memory, and sync separator to obtain correct digital data.

A/D Converter. The A/D converter digitizes the analog input signal to 10-bits digital data for genlock operation. This data is read by the CPU and used to control the master oscillator frequency.

Sync Separator. The sync separator separates the sync signal such as H sync or V sync from the input signal.

Amp & Restorer. This block consists of amplifiers to adjust the amplitude of the signal from the REF input and restorer to recover the DC component of the signal.

Analog Generator (A10 Main Board Only)

The analog generator consists of the following blocks:

Sync Memory. The sync memory is a part of the FPGA and keeps the data of the sync pulses.

Line Memory. The line memory is a part of the FPGA and contains the active part of the line data of the test signal. It can store up to four line data.

Frame Memory. The frame memory contains a series of pointers that control the order of the video lines stored in the Line Memory, which are used to produce digital signals.

Overlay Memory. The overlay memory generates timings to multiplex the line memory data and the overlay data used for an ID text and logo overlay.

Delay Counter. The delay counter in the FPGA sets the timing of each channel. The optional fine timing feature is achieved by digital filter technique.

Signal Generator. This block builds complete test signal sequence with sync and line data according to the frame memory.

D/A Converter and Amplifier. This block consists of a D/A converter, an amplifier, and a filter. It converts the digital data from the Signal Generator to an analog signal and reconstructs the signal for output.

SDI Generator

The SDI generator consists of the following blocks:

Sync Memory. The sync memory is a part of the FPGA and stores the EAV and SAV data.

Line Memory. The line memory is a part of the FPGA and contains the active part of the line data of the test signal. It can store up to four line data.

Frame Memory. The frame memory contains a series of pointers that control the order of the video lines stored in the Line Memory, which are used to produce digital signals.

Overlay Memory. The overlay memory generates timing to multiplex the line memory data and the overlay data used for an ID text and logo overlay.

Delay Counter. The delay counter in the FPGA sets the timing of each channel.

Signal Generator. This block builds complete test signal sequence with black and line data according to the frame memory.

Embedded Packet Generator. This block generates 16-channel embedded audio data.

Serializer. This block converts a 10-bit parallel data to SDI signal.

Audio Generator The audio generator consists of the following blocks:

Audio Memory. The audio memory contains the data for both analog and AES/EBU packet generators.

Analog Waveform Generator. The generator obtains the data from the audio memory and builds the analog waveform.

D/A Converter and Amplifier. This block contains two set of D/A converters and amplifiers for generating left and right signals. The D/A converter receives the data from the analog waveform generator and converts them to an analog signal. The amplifier amplifies the signal to the desired level.

AES/EBU Packet Generator and Word Clock. The packet generator creates the AES/EBU packets based on the memory contents. Word clock generates a 48 kHz clock signal.

Drivers. This block contains four driver circuits for AES/EBU and a driver for the word clock. The drivers set the output amplitude and impedance.

A20 Front-Panel Board

The A20 Front-Panel board consists of the rubber contact switches and three LEDs.

Power Supply Module

The power supply module derives the +5 V power supply voltages from the AC line and supplies them to the A10 Main board.

A30 Analog Board (SPG600 Option 02) and A50 Analog Board (SPG300)

The A30/A50 Analog board consists of the same blocks as the Analog Generator. Refer to *Analog Generator* on page 3-2.

A40 SDI Board (SPG600 Option 03)

The A40 SDI board consists of the same blocks as the SDI generator. Refer to *SDI Generator* on page 3-2.



Performance Verification

Performance Verification

This section provides procedures to verify the performance and functionality of the sync pulse generator.

Preparation for Performance Verification

Do the following before starting the performance verification procedures:

Power On Default Settings

Before you begin the performance verification procedures, make sure that the required instrument settings are saved in the Power On Default preset.

If the instrument settings are saved in the Power On Default preset, you can recall the settings after the performance verification procedures are completed by turning off and on the power.

Warm up

The sync pulse generator and test equipment must have had a warm-up period of at least 20 minutes.

Equipment Required

Table 4-1 lists the equipment required for this procedure.

Table 4-1: Equipment required for performance verification

Item	No.	Minimum requirement	Recommended equipment
Frequency counter	1	Frequency range: 0.1 Hz to 1250 MHz Precision: 7 digits or higher	ANRITSU MF 1603A
Oscilloscope	1	Bandwidth: 200 MHz or higher	Tektronix TDS3032B
Video measurement set	1		Tektronix VM700T Option 01/11/1S/40
Waveform vector monitor	1		Tektronix 1765
Digital audio monitor	1		Tektronix 764
TV signal generator	1		Tektronix TG700 with AGL7 Analog Genlock module
75 Ω BNC cable	3	Length: 42 inches	Tektronix part no. 012-0074-00
75 Ω feed-through terminator	1		Tektronix part no. 011-0103-02
75 Ω coaxial terminator	2		Tektronix part no. 011-0102-01
XLR cable	1		CANARE DAC01-SA
Female XLR to male mini-XLR adapter cable	2		Standard accessories of the VM700T Option 40

Calibration Data Report

Photocopy this form and use it to record the performance test results.

Table 4-2: SPG600 and SPG300 calibration data report

Serial Number:		Cal Data:		Temperature:		Humidity:	
Step	Function Tested	Minimum	Cal Data	Cal Data		Maximum	
1.	Subcarrier Frequency	3.5795444 MHz				3.5795464 MHz	
2.	Blanking Level	CH 1	-50 mV	mV	+50 mV		
		CH 2	-50 mV	mV	+50 mV		
		CH 3	-50 mV	mV	+50 mV		
		CH 4	-50 mV	mV	+50 mV		
3.	Burst Amplitude	CH 1	271.4 mV	mV	286.4 mV		
		CH 2	271.4 mV	mV	286.4 mV		
		CH 3	271.4 mV	mV	286.4 mV		
		CH 4	271.4 mV	mV	286.4 mV		
4.	Sync Amplitude	CH 1	277.1 mV	mV	294.3 mV		
		CH 2	277.1 mV	mV	294.3 mV		
		CH 3	277.1 mV	mV	294.3 mV		
		CH 4	277.1 mV	mV	294.3 mV		
5.	48 kHz Clock Output Level (CMOS compatible)	High	2.1 V	OK			
		Low		OK		0.8 V	
6.	AES/EBU Serial Digital Audio Output Level (SPG600 Only)	1+2	900 mV	mV	1100 mV		
		3+4	900 mV	mV	1100 mV		
		5+6	900 mV	mV	1100 mV		
		7+8	900 mV	mV	1100 mV		
SPG600 Option 02							
7.	Blanking Level	CH 5	-50 mV	mV	+50 mV		
		CH 6	-50 mV	mV	+50 mV		
		CH 7	-50 mV	mV	+50 mV		
		CH 8	-50 mV	mV	+50 mV		
8.	Burst Amplitude	CH 5	271.4 mV	mV	286.4 mV		
		CH 6	271.4 mV	mV	286.4 mV		
		CH 7	271.4 mV	mV	286.4 mV		
		CH 8	271.4 mV	mV	286.4 mV		

Table 4-2: SPG600 and SPG300 calibration data report (cont.)

Serial Number:		Cal Data:	Temperature:	Humidity:	
Step	Function Tested	Minimum	Cal Data	Maximum	
9.	Sync Amplitude				
		CH 5	277.1 mV	mV	294.3 mV
		CH 6	277.1 mV	mV	294.3 mV
		CH 7	277.1 mV	mV	294.3 mV
		CH 8	277.1 mV	mV	294.3 mV
10.	Serial Output Amplitude				
		SDI 1	720 mV	mV	880 mV
		SDI 2	720 mV	mV	880 mV
11.	Serial Output Rise Time (20% to 80% amplitude points)				
		SDI 1	0.4 ns	ns	1.50 ns
		SDI 2	0.4 ns	ns	1.50 ns
12.	Serial Output Fall Time (20% to 80% amplitude points)				
		SDI 1	0.4 ns	ns	1.50 ns
		SDI 2	0.4 ns	ns	1.50 ns
SPG600 Option 03					
13.	Serial Output Amplitude				
		SDI 5	720 mV	mV	880 mV
		SDI 6	720 mV	mV	880 mV
14.	Serial Output Rise Time (20% to 80% amplitude points)				
		SDI 5	0.4 ns	ns	1.50 ns
		SDI 6	0.4 ns	ns	1.50 ns
15.	Serial Output Fall Time (20% to 80% amplitude points)				
		SDI 5	0.4 ns	ns	1.50 ns
		SDI 6	0.4 ns	ns	1.50 ns

Performance Verification Procedures

NOTE. The performance verification procedures are common for both the SPG600 and SPG300 except for optional output connectors.

You must perform the *Preparation for Performance Verification* (on page 4-1) before proceeding.

Subcarrier Frequency

This test verifies the subcarrier frequency accuracy of black burst signals. The following equipment is required for the test:

- Frequency counter
- 75 Ω BNC cable
- 75 Ω feed-through terminator

Perform the following procedure to verify the subcarrier frequency accuracy of the black burst signal.

1. Use the 75 Ω BNC cable and the 75 Ω feed-through terminator to connect the CH 4 connector on the sync pulse generator to the INPUT A connector on the frequency counter. See Figure 4-1.

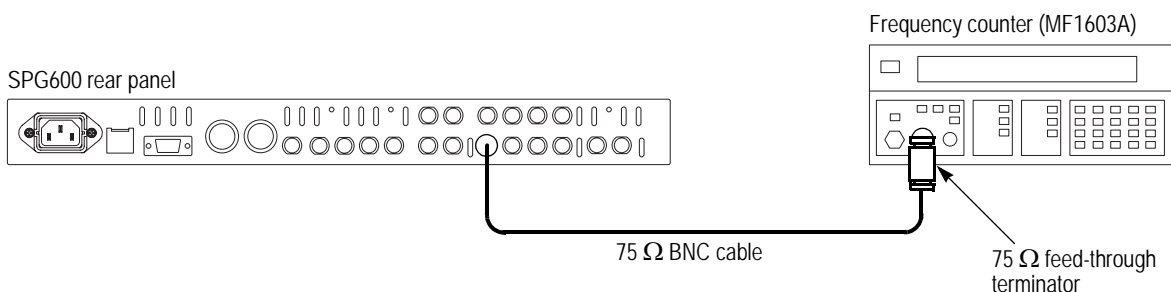

Figure 4-1: Equipment connection for verifying subcarrier frequency

2. Set the frequency counter to the frequency measurement mode (if necessary), and then set the Gate Time to $< 2s$.
3. Output the NTSC subcarrier calibration signal as follows:
 - a. Press the **VIDEO**, **GENLOCK**, and **PANEL ENABLE** buttons simultaneously, and then release the **VIDEO** and **GENLOCK** buttons to restart the instrument in Factory mode.
 - b. Press the **SYSTEM** button to display the System menu.
 - c. Press the up (\blacktriangle) or down (\blacktriangledown) arrow button to select **CONFIGURATION**.

- d. Press the **ENTER** button.
 - e. Press the up (▲) or down (▼) arrow button to select **VIDEO STANDARD**.
 - f. Press the **ENTER** button.
 - g. Press the left (◀) or right (▶) arrow button to select **3.58 MHz**.
 - h. Press the **ENTER** button.
4. Set the frequency counter to trigger on the input.
 5. Verify that the displayed frequency is within the range of 3.5795444 MHz to 3.5795464 MHz.

Genlock Function

This test verifies that the genlock function is operating correctly. The following equipment is required for the test:

- TV signal generator (TG700 mainframe with AGL7 module)
- Waveform vector monitor
- Three 75 Ω BNC cables
- Two 75 Ω coaxial terminators

Perform the following procedure to verify that the genlock function is functioning correctly.

1. Use a 75 Ω BNC cable to connect the REF connector on the sync pulse generator to the BLACK 1 connector on the TV signal Generator (AGL7 module). See Figure 4-2.
2. Use a 75 Ω BNC cable to connect the other REF connector on the sync pulse generator to the A connector on the waveform vector monitor. See Figure 4-2.
3. Use a 75 Ω BNC cable to connect the CH 1 connector on the sync pulse generator to the B connector on the waveform vector monitor. See Figure 4-2.
4. Use the 75 Ω coaxial terminators to terminate the A and B loop through connectors on the waveform vector monitor rear panel. See Figure 4-2.

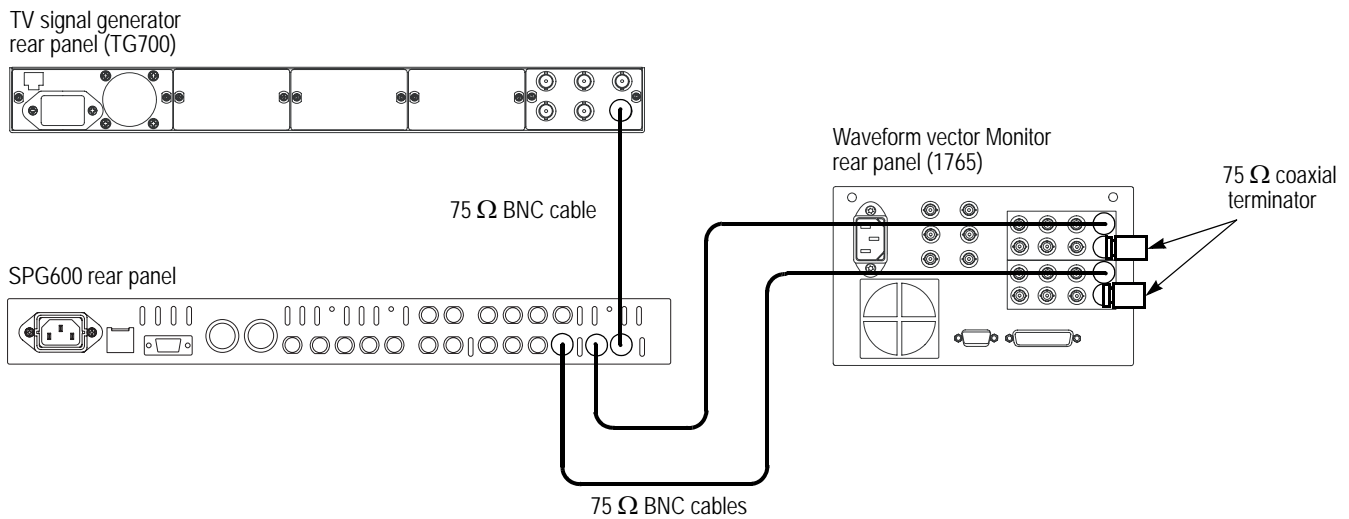

Figure 4-2: Equipment connections for verifying the genlock function

5. Set the TV signal generator (AGL7 module) settings as indicated below:
 - Signal format PAL
 - Test signal Black Burst
6. Set the waveform vector monitor settings as indicated below:
 - CONFIG REFERENCE
 - NTSC EXTREF: A
 - PAL EXTREF: B
 - DISPLAY VECTOR
 - INPUT CH-A and CH-B
 - OVERLAY ON
 - EXT REF OFF
7. Press the **GAIN** menu button on the waveform vector monitor front panel to display the Gain menu.
8. In the Gain menu, select X5 and VARIABLE.
9. Align the PAL burst vector with the compass rose of the display.
10. Recall the Factory Default preset as follows:
 - a. Press the **SYSTEM** button to display System menu.
 - b. Press the **ENTER** button to display the Preset submenu.
 - c. Press the left (◀) or right (▶) arrow button to select **Factory Default**.
 - d. Press the **ENTER** button to recall the factory default settings.

11. Set the output signal format and genlock source of the sync pulse generator as follows:
 - a. Press the **CANCEL** button to return the **SYSTEM** menu.
 - b. Press the up (▲) or down (▼) arrow button to select **CONFIGURATION**.
 - c. Press the **ENTER** button to display the Configuration submenu.
 - d. Press the left (◀) or right (▶) arrow button to select **PAL**.
 - e. Press the **ENTER** button.
 - f. Press the **GENLOCK** button to display the Genlock menu.
 - g. Press the up (▲) or down (▼) arrow button to select **GENLOCK SOURCE**.
 - h. Press the left (◀) or right (▶) arrow button to select **PAL Burst**.
 - i. Press the **ENTER** button.
12. Verify that the vector display is locked and that the **EXT.REF** LED on the sync pulse generator lights.
13. Press the left (◀) or right (▶) arrow button to select **NTSC Burst**.
14. Press the **ENTER** button.
15. Verify that the vector display is unlocked.
16. Press the left (◀) or right (▶) arrow button to select **625 SYNC**.
17. Press the **ENTER** button.
18. Verify that the vector display is locked.
19. Change the signal format setting of the TV signal generator (AGL7 module) to NTSC.
20. Change the sync pulse generator settings as follows:
 - a. Press the **SYSTEM** button to display the System menu.
 - b. Press the up (▲) or down (▼) arrow button to select **CONFIGURATION**.
 - c. Press the **ENTER** button to display the Configuration submenu.
 - d. Press the left (◀) or right (▶) arrow button to select **NTSC**.
 - e. Press the **ENTER** button.
 - f. Press the **GENLOCK** button to display the Genlock menu.

Black Burst Output

This test verifies the blanking level, burst amplitude, and sync amplitude of black burst signals. The following equipment is required for the test:

- Video measurement set
- 75 Ω feed-through termination
- 75 Ω coaxial terminator
- 75 Ω BNC cable

Perform the following procedure to verify the blanking level, burst amplitude, and sync amplitude of black burst signals.

1. Use the 75 Ω BNC cable to connect the CH 1 connector on the sync pulse generator to the CHAN A connector on the video measurement set. See Figure 4-3.
2. Use the 75 Ω coaxial terminator to terminate the other loop through to the CHAN A connector on the video measurement set. See Figure 4-3.

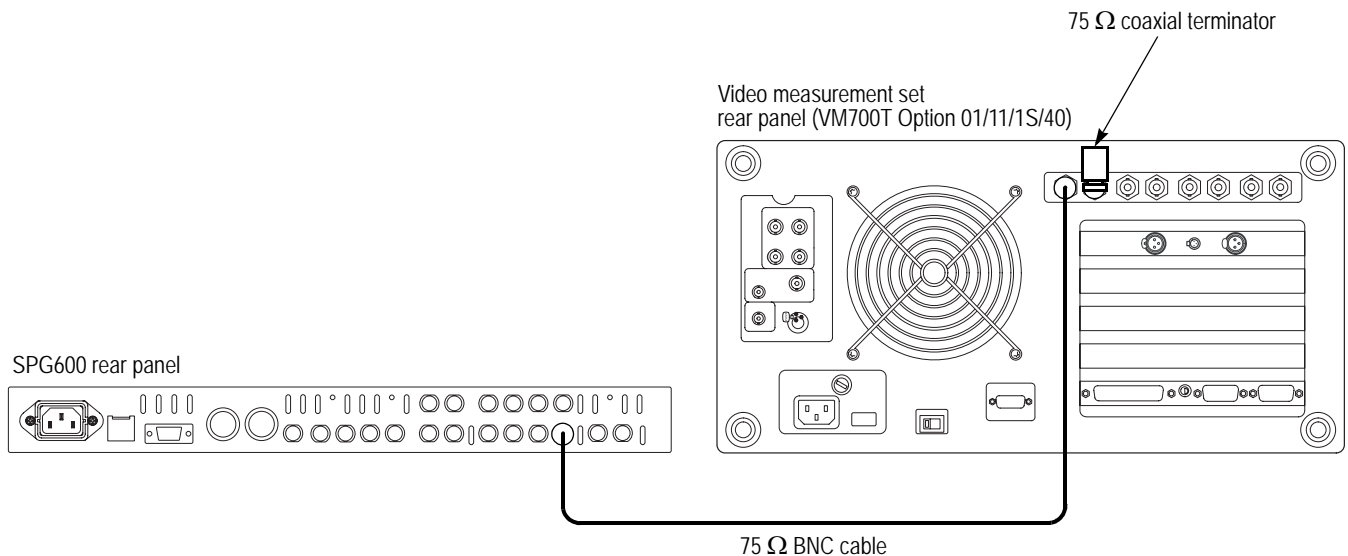

Figure 4-3: Equipment connection for verifying the blanking level

3. Recall the Factory Default preset as follows:
 - a. Press the **SYSTEM** button to display the System menu.
 - b. Press the **ENTER** button to display the Preset submenu.
 - c. Press the left (**◀**) or right (**▶**) arrow button to select **Factory Default**.
 - d. Press the **ENTER** button to recall the factory default settings.

4. Press the **Measure** button on the video measurement set to open the Measure mode display.
5. Touch the **Level Meter** soft key.
6. Press the **Menu** button to display the Level Meter main menu.
7. Touch the **Measure Position** soft key to display the Measure Position submenu.
8. Touch the **Dc Cpl. ABS. Meas.** soft key.
9. Verify that the blanking level is within the range of +50 mV to -50 mV.
10. Move the BNC cable connection from the CH 1 connector to the CH 2 connector on the sync pulse generator.
11. Repeat step 9.
12. Move the BNC cable connection from the CH 2 connector to the CH 3 connector on the sync pulse generator.
13. Repeat step 9.
14. Move the BNC cable connection from the CH 3 connector to the CH 4 connector on the sync pulse generator.
15. Repeat step 9.
- SPG600 Option 02 Only.** Perform steps 16 through 23 if Option 02 is installed in your SPG600.
16. Move the BNC cable connection from the CH 4 connector to the CH 5 connector on the sync pulse generator.
17. Repeat step 9.
18. Move the BNC cable connection from the CH 5 connector to the CH 6 connector on the sync pulse generator.
19. Repeat step 9.
20. Move the BNC cable connection from the CH 6 connector to the CH 7 connector on the sync pulse generator.
21. Repeat step 9.
22. Move the BNC cable connection from the CH 7 connector to the CH 8 connector on the sync pulse generator.
23. Repeat step 9.

24. Move the BNC cable connection from the CH 4 (or CH 8) connector to the CH 1 connector on the sync pulse generator.
 25. Press the **Measure** button on the video measurement set to open the Measure mode display.
 26. Touch the Mode soft key to set the instrument to Analog mode, and then touch the **H_Timing** soft key.
 27. Press the **Menu** button to display the H_Timing main menu.
 28. Touch the **Average** soft key and rotate the front-panel knob to set the value to 32.
 29. Touch the **RS-170A** soft key.
 30. Press the **Select Line** button.
 31. Rotate the front-panel knob to set the measurement line to 100 (Field=1, Line=100).
 32. Verify that the burst amplitude is within the range of 271.4 mV to 286.4 mV.
 33. Verify that the sync amplitude is within the range of 277.1 mV to 294.3 mV.
 34. Move the BNC cable connection from CH 1 connector to the CH 2 connector on the sync pulse generator.
 35. Repeat steps 32 and 33.
 36. Move the BNC cable connection from CH 2 connector to the CH 3 connector on the sync pulse generator.
 37. Repeat steps 32 and 33.
 38. Move the BNC cable connection from CH 3 connector to the CH 4 connector on the sync pulse generator.
 39. Repeat steps 32 and 33.
- SPG600 Option 02 Only.** Perform steps 40 through 47 if Option 02 is installed in your SPG600.
40. Move the BNC cable connection from CH 4 connector to the CH 5 connector on the sync pulse generator.
 41. Repeat steps 32 and 33.
 42. Move the BNC cable connection from CH 5 connector to the CH 6 connector on the sync pulse generator.
 43. Repeat steps 32 and 33.

44. Move the BNC cable connection from CH 6 connector to the CH 7 connector on the sync pulse generator.
45. Repeat steps 32 and 33.
46. Move the BNC cable connection from CH 7 connector to the CH 8 connector on the sync pulse generator.
47. Repeat steps 32 and 33.

Serial Digital Output

This test verifies that serial digital signals are output correctly from the SDI 1 and SDI 2 connectors. The following equipment is required for the test:

- Video measurement set
- 75 Ω BNC cable
- 75 Ω coaxial terminator

Perform the following procedure to verify that serial digital signals are output correctly from the SDI 1 and SDI 2 connectors.

1. Use the 75 Ω BNC cable to connect SDI 1 connector on the sync pulse generator to the SDI Ch.A connector on the video measurement set rear panel. See Figure 4-4.
2. Use the 75 Ω coaxial terminator to terminate the other loop through to the SDI Ch.A connector on the video measurement set rear panel. See Figure 4-4.

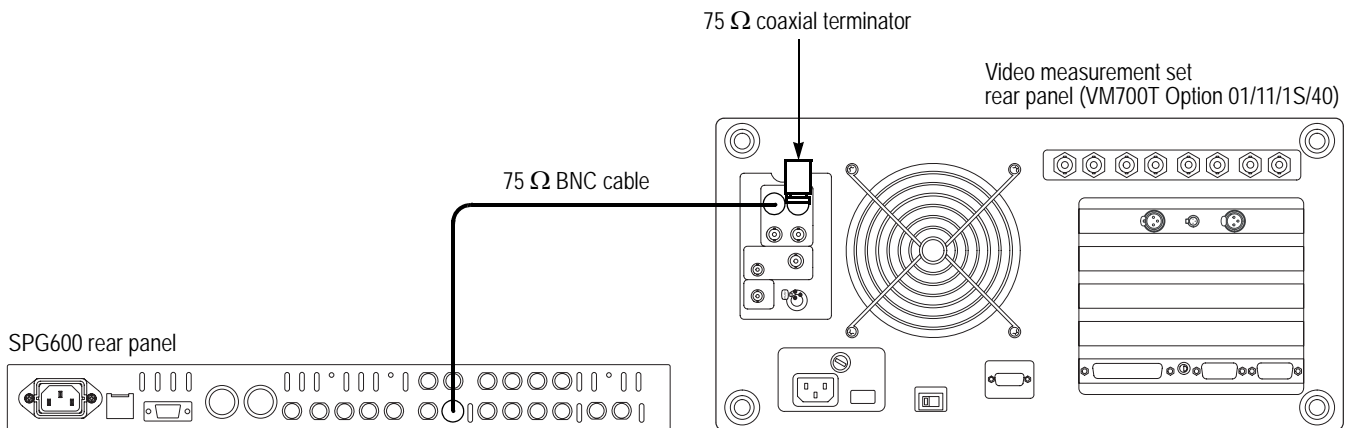

Figure 4-4: Equipment connection for verifying the serial digital outputs

3. Recall the Factory Default preset as follows:
 - a. Press the **SYSTEM** button to display the System menu.
 - b. Press the **ENTER** button to display the Preset submenu.
 - c. Press the left (◀) or right (▶) arrow button to select **Factory Default**.
 - d. Press the **ENTER** button to recall the factory default settings.
4. Select the **75% Color Bars** signal as follows:
 - a. Press the **VIDEO** button to display the Video menu.
 - b. Press the up (▲) or down (▼) arrow button to select **TEST SIGNAL (SDI)**.
 - c. Press the **ENTER** button.
 - d. Press the left (◀) or right (▶) arrow button to select **75% Color Bars**.
5. Turn on the logo overlay as follows:
 - a. Press the **CANCEL** button to return the Video menu.
 - b. Press the up (▲) or down (▼) arrow button to select **OVERLAY**.
 - c. Press the left (◀) or right (▶) arrow button to select **SDI (STD)**.
 - d. Press the **ENTER** button to display the Overlay submenu.
 - e. Press the left (◀) or right (▶) arrow button to select **Logo**.
 - f. Press the **ENTER** button to display the Logo submenu.
 - g. Press the left (◀) or right (▶) arrow button to select a logo.
6. Turn on the embedded audio for Group 1 as follows:
 - a. Press the **AUDIO** button to display the Audio menu.
 - b. Press the up (▲) or down (▼) arrow button to select **EMBEDDED (STD/TEST)**.
 - c. Press the left (◀) or right (▶) arrow button to select **Group 1**.
 - d. Press the **ENTER** button to display the Embedded submenu.
 - e. Press the left (◀) or right (▶) arrow button to select **Enable**.
 - f. Press the **ENTER** button.
7. Press the **Measure** button on the video measurement set to open the Measure mode display.

8. Touch the **SDI** soft key to set the video measurement set to Digital mode.
 9. In the Measurement mode display, touch the **SDI Format** application.
 10. Verify that no error messages appears on the SDI Format Monitor display.
 11. Press the **Picture** button to set the video measurement set to **SDI Picture** application.
 12. Verify that the correct color bars and overlay logo are displayed on the SDI Picture display.
 13. Press the **Measure** button on the video measurement set to open the Measure mode display.
 14. In the Measure mode display, touch the **SDI Audio Format** application.
 15. Verify that no CRC errors appear on the SDI Audio Format Analyzer display.
 16. Move the BNC cable from the SDI 1 connector to the SDI 2 connector on the sync pulse generator.
 17. Press the **Measure** button on the video measurement set to open the Measure mode display.
 18. Repeat steps 9 through 15.
- SPG600 Option 03 Only.** Perform steps 19 through 24 if Option 03 is installed in your SPG600.
19. Move the BNC cable from the SDI 2 connector to the SDI 3 connector on the sync pulse generator.
 20. Press the **Measure** button on the video measurement set to open the Measure mode display.
 21. Repeat steps 9 through 15.
 22. Move the BNC cable from the SDI 3 connector to the SDI 4 connector on the sync pulse generator.
 23. Press the **Measure** button on the video measurement set to open the Measure mode display.
 24. Repeat steps 9 through 15.

Eye Pattern Check

This test verifies the signal level and rise/fall times of the SDI 1 and SDI 2 outputs. The following equipment is required for the test:

- Video measurement set
- 75 Ω BNC cable
- 75 Ω coaxial terminator

Perform the following procedure to verify the signal level and rise/fall times of the SDI 1 and SDI 2 outputs.

Use the equipment connection and controls from the previous test.

1. Press the **Measure** button on the video measurement set to open the Measure mode display.
2. In the Measure mode display, touch the **SDI Eye Diagram** application to open the Eye Diagram display.
3. Push the **Menu** button.
4. In the Eye Diagram display, touch the **Average** soft key to set the value for Eye Persistence to **Infinity**.
5. In the Eye Diagram display, touch the **Measure** soft key to open the Measure submenu.
6. In the Measure submenu, touch the following soft keys to toggle each measurement display on: **Eye Amplitude**, **Rise\Fall Times**, and **Rise\Fall Adjusted**.
7. Verify that the eye amplitude and rise and fall times values are as follows:
Eye amplitude: 720 mV to 880 mV
Rise and fall time: 400 ps to 1500 ps
8. Change the BNC cable connection from the SDI 1 connector to the SDI 2 connector.
9. Repeat step 7.
SPG600 Option 03 Only. Perform steps 9 through 12 if Option 03 is installed in your SPG600.
9. Change the BNC cable connection from the SDI 2 connector to the SDI 3 connector.
10. Repeat step 7.

11. Change the BNC cable connection from the SDI 3 connector to the SDI 4 connector.
12. Repeat step 7.

AES/EBU Digital Audio Outputs (SPG600 Only)

This test verifies that AES/EBU digital audio signals are output correctly from the AES 1+2, AES 3+4, AES 5+6, and AES 7+8 connectors. The following equipment is required for this test:

- Oscilloscope
- Digital audio monitor
- 75 Ω BNC cable
- 75 Ω feed-through terminator
- 75 Ω coaxial terminator

Perform the following procedure to verify that AES/EBU digital audio signals are output correctly from the AES 1+2, AES 3+4, AES 5+6, and AES 7+8 connectors.

1. Use the 75 Ω BNC cable and the 75 Ω feed-through terminator to connect the AES 1+2 connector on the sync pulse generator to the oscilloscope CH1 input. See Figure 4-5.

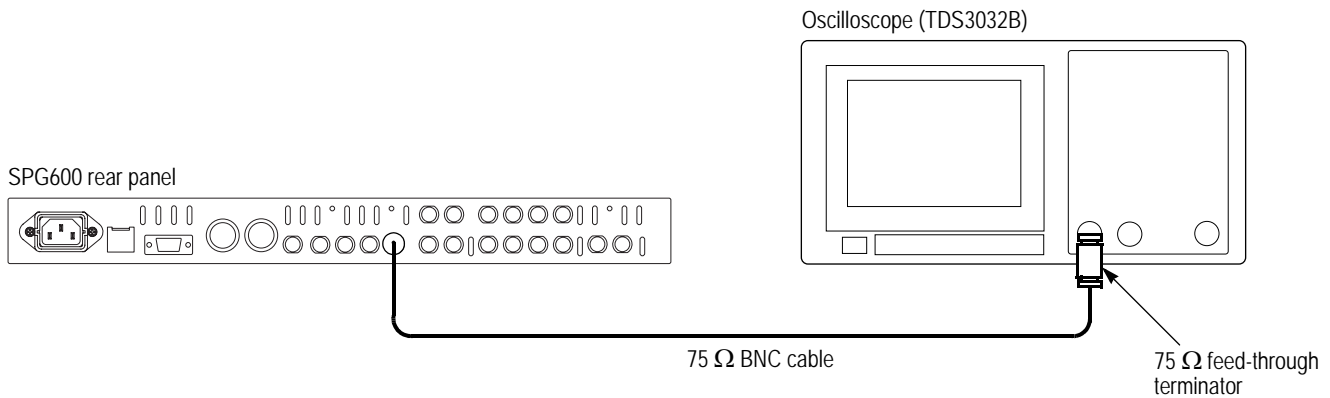

Figure 4-5: Initial equipment connection for verifying the serial digital audio outputs

2. Set the oscilloscope settings as indicated below:

Vertical 200 mV/div
 Horizontal 100 ns/div
 Acquire menu Sample
 Measure Amplitude
 Trig slope Rising Edge
 Input impedance 1 MΩ

3. Recall Factory Default preset as follows:
 - a. Press the **SYSTEM** button to display the System menu.
 - b. Press the **ENTER** button to display the Preset submenu.
 - c. Press the left (◀) or right (▶) arrow button to select **Factory Default**.
 - d. Press the **ENTER** button to recall the factory default settings.
4. Use the oscilloscope to measure that the signal amplitude is within the range of 900 mV to 1100 mV.
5. Change the BNC cable connection from the AES 1+2 connector to the AES 3+4 connector on the sync pulse generator.
6. Repeat step 4.
7. Change the BNC cable connection from the AES 3+4 connector to the AES 5+6 connector on the sync pulse generator.
8. Repeat step 4.
9. Change the BNC cable connection from the AES 5+6 connector to the AES 7+8 connector on the sync pulse generator.
10. Repeat step 4.
11. Disconnect the BNC cable and the 75 Ω terminator from the oscilloscope CH1 input connector, and then connect the BNC cable to the CH1-2 BNC connector on the digital audio monitor rear panel. See Figure 4-6.
12. Use the 75 Ω coaxial terminator to terminate the other loop through to the CH1-2 BNC connector on the digital audio monitor rear-panel.

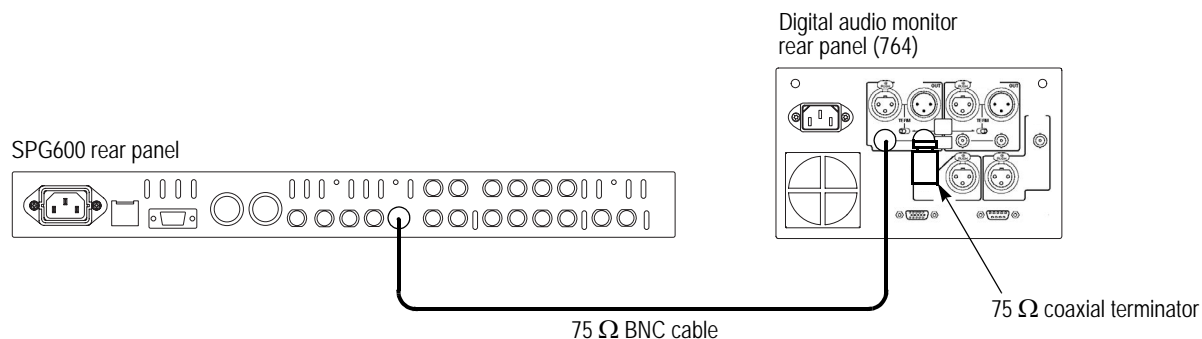

Figure 4-6: Second equipment connection for verifying the serial digital audio outputs

13. On the digital audio monitor front panel, press the **MENU** button to display the Top menu.
14. Select **Inputs** from the Top menu
15. Select **CH1-2 input: BNC-unbalanced** from the submenu.
16. On the digital audio monitor front panel, press the **CLEAR MENU** button to clear the menu.
17. On the digital audio monitor front panel, press the **CH STATUS** button to display **Channel Status** view.
18. Check that no CRC errors appear on the monitor.
19. On the digital audio monitor front panel, press the **AUDIO** button to display the **Audio/Session** view.
20. Verify that the digital audio monitor bar graphs show both Channel 1 and Channel 2 at -20 dBFS.
21. Change the BNC cable connection from AES 1+2 connector to the AES 3+4 connector on the sync pulse generator.
22. Repeat steps 17 through 20.
23. Change the BNC cable connection from AES 3+4 connector to the AES 5+6 connector on the sync pulse generator.
24. Repeat steps 17 through 20.
25. Change the BNC cable connection from AES 5+6 connector to the AES 7+8 connector on the sync pulse generator.
26. Repeat steps 17 through 20.
27. Disconnect the BNC cable from the sync pulse generator and digital audio monitor.

XLR Digital Audio Outputs

This test verifies that AES/EBU digital audio signals are output correctly from the 1+2/RIGHT and 3+4/LEFT XLR connectors. The following equipment is required for this test:

- Digital audio monitor
- XLR cable

Perform the following procedure to verify that AES/EBU digital audio signals are output correctly from the 1+2/RIGHT and 3+4/LEFT XLR connectors.

1. Use the XLR cable to connect the 1+2/RIGHT connector on the sync pulse generator to the CH 1-2 XLR connector on the digital audio monitor rear panel. See Figure 4-7.

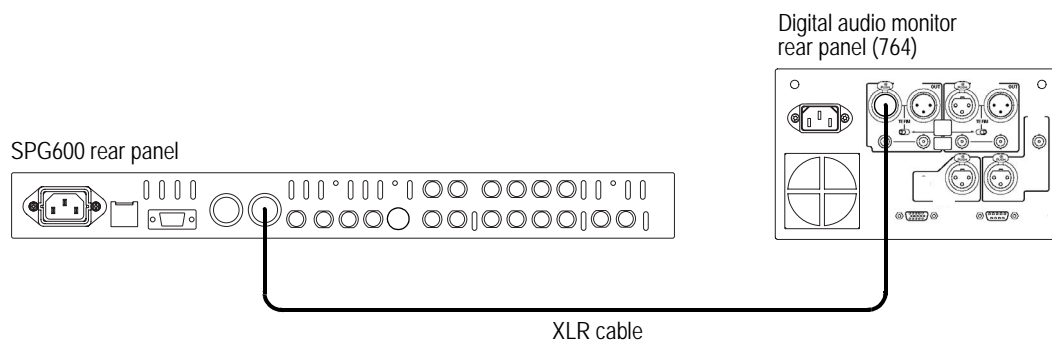

Figure 4-7: Equipment connection for verifying the XLR digital audio outputs

2. On the digital audio monitor front panel, press the **MENU** button to display the Top menu.
3. Select **Inputs** from the Top menu.
4. Select **CH1-2 input: XLR-balanced** from the submenu.
5. On the digital audio monitor front panel, press the **CLEAR MENU** button to clear the menu.
6. On the digital audio monitor front panel, press the **CH STATUS** button to display the **Channel Status** view.
7. Check that no CRC errors appear on the monitor.
8. Change the XLR cable connection from the 1+2/RIGHT connector to the 3+4/LEFT connector on the sync pulse generator.
9. Repeat step 7.
10. Change the XLR cable connection from the 3+4/LEFT connector to the 1+2/RIGHT connector on the sync pulse generator.

11. On the digital audio monitor front panel, press the **AUDIO** button to display **Audio/Session** view.
12. Verify that the digital audio monitor bar graphs show both Channel 1 and Channel 2 at -20 dBFS.
13. Change the XLR cable connection from the 1+2/RIGHT connector to the 3+4/LEFT connector on the sync pulse generator.
14. Repeat step 12.

XLR Analog Audio Outputs

This test verifies that analog audio signals are output correctly from the 1+2/RIGHT and 3+4/LEFT XLR connectors. The following equipment is required for this test:

- Video measurement set
- Two female XLR to male mini-XLR adapter cables

Perform the following procedure to verify that analog audio signals are output correctly from the 1+2/RIGHT and 3+4/LEFT XLR connectors.

1. Use the female XLR to male mini-XLR adapter cable to connect the 1+2/RIGHT connector on the sync pulse generator to the RIGHT INPUT connector on the video measurement set. See Figure 4-8.
2. Use the female XLR to male mini-XLR adapter cable to connect the 3+4/LEFT connector on the sync pulse generator to the LEFT INPUT connector on the video measurement set. See Figure 4-8.

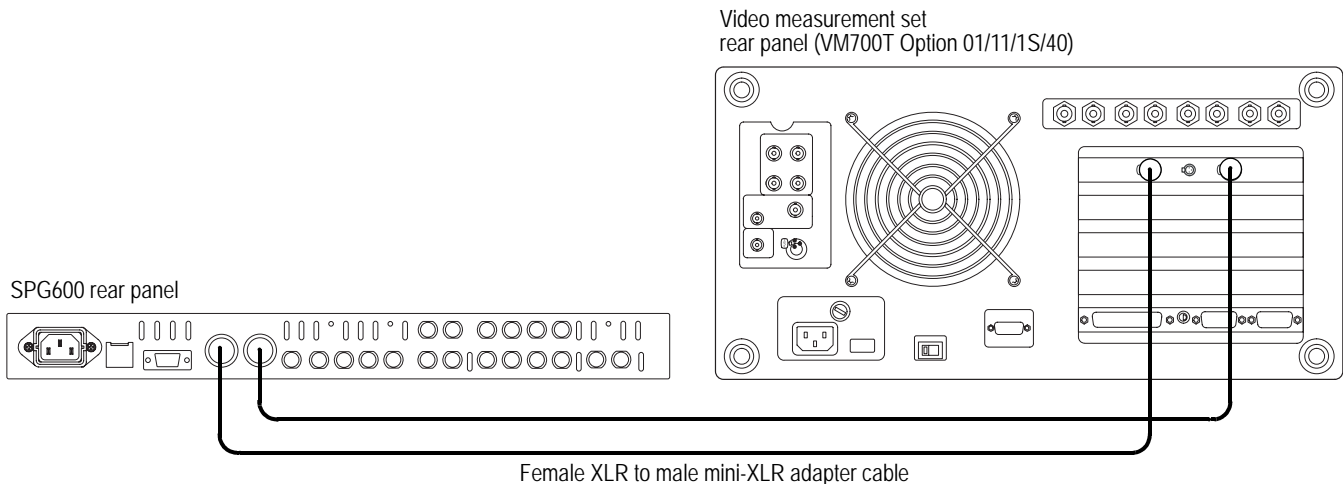

Figure 4-8: Equipment connection for verifying the XLR analog audio outputs

3. Recall the Factory Default preset as follows:
 - a. Press the **SYSTEM** button to display the System menu.
 - b. Press the **ENTER** button to display the Preset submenu.
 - c. Press the left (◀) or right (▶) arrow button to select **Factory Default**.
 - d. Press the **ENTER** button to recall the factory default settings.
4. Output analog audio signals from the XLR connectors as follows:
 - a. Press the **CANCEL** button to return to the System menu.
 - b. Press the up (▲) or down (▼) arrow button to select **CONFIGURATION**.
 - c. Press the **ENTER** button to display the Configuration submenu.
 - d. Press the up (▲) or down (▼) arrow button to select **XLR OUTPUT**.
 - e. Press the left (◀) or right (▶) arrow button to select **Analog Audio**.
 - f. Press the **ENTER** button.
5. Press the **Measure** button on the video measurement set to open the Measure mode display.
6. In the Measure mode display, touch the **Audio** soft key.
7. Touch the **Audio Analyzer** soft key to open the Audio Analyzer display
8. Verify that the frequency, level, and THD+N values are as follows:

Frequency: 1 kHz
Level: -1 dBu to +1 dBu
THD+N: < 0.5%

48 kHz Clock Output

This test verifies that a 48 kHz clock signal is output correctly from the WORD CLK connector. The following equipment is required for this test.

- Oscilloscope
- 75 Ω BNC cable

Perform the following procedure to verify that a 48 kHz clock signal is output correctly from the WORD CLK connector.

1. Use the 75 Ω BNC cable to connect the WORD CLK connector on the sync pulse generator to the oscilloscope CH1 input. See Figure 4-9.

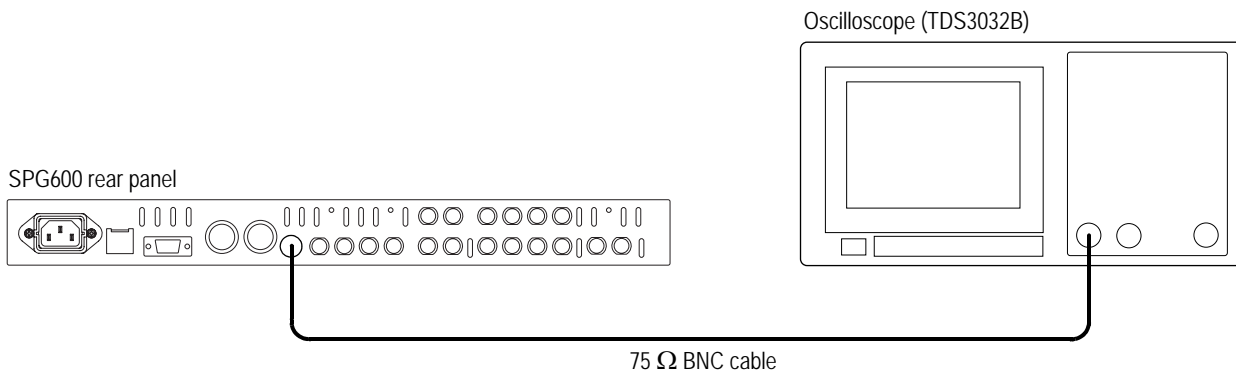

Figure 4-9: Equipment connection for verifying the 48 kHz clock output

2. Set the oscilloscope settings as indicated below:

Vertical 1 V/div
 Horizontal 10 μs/div
 Acquire menu Sample
 Measure High and Low
 Trig position 50%
 Trig slope Rising Edge
 Input impedance 1 MΩ

3. Use the oscilloscope to measure that the signal amplitude is as follows:

Low: < 0.8 V
 High: > 2.1 V

This completes the *Performance Verification* procedure. If you require further assistance, contact your nearest Tektronix Service Center.



Adjustment

Adjustment Procedure

This section contains information needed to adjust the sync pulse generator.

The only adjustment in the sync pulse generator is for the master clock frequency.

Requirement for Adjustment

Before proceeding, note the following requirement:

Warm-up Period The sync pulse generator requires a 20 minute warm-up time in a +20 °C to +30 °C environment before it is adjusted. Adjustment done before the operating temperature has stabilized may cause errors in performance.

In addition, the signal generator requires appropriate warm-up time to meet the frequency accuracy.

Equipment Required

Table 5-1 lists the equipment required to adjust the master clock frequency.

Table 5-1: Equipment required

Item	No.	Minimum requirement	Recommended equipment
Signal generator	1	Frequency: 10 MHz \pm 0.05 ppm Amplitude: 8 dBm	Agilent 8648A option 1E5
75 Ω BNC cable	1	Length: 42 inches	Tektronix part no. 012-0074-00
50 Ω -to-75 Ω minimum loss attenuator	1		Tektronix part no. 011-0057-01
75 Ω coax terminator	1	Length: 42 inches	Tektronix part no. 011-0102-01

Master Clock Frequency Adjustment

Procedure Perform the following procedure to adjust the master clock frequency.

Initial Setups.

Signal Generator:

Frequency 10.000000 MHz

Output level. 8 dBm

Procedure.

1. Use the 75 Ω BNC cable and the 50 Ω -to-75 Ω minimum loss attenuator to connect the REF connector on the sync pulse generator to the output connector on the signal generator as shown in Figure 5-1.
2. Use the 75 Ω coax terminator to terminate the other REF connector on the sync pulse generator as shown in Figure 5-1.

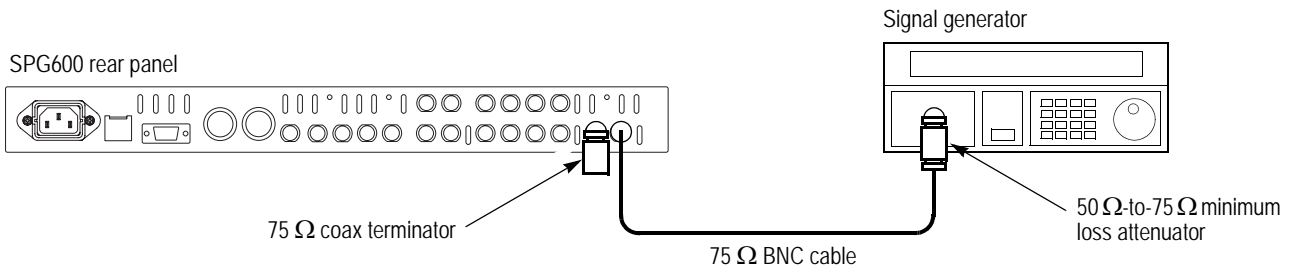

Figure 5-1: Equipment connection for adjusting master clock frequency

3. Press the **VIDEO**, **GENLOCK**, and **PANEL ENABLE** buttons simultaneously, and then release the **VIDEO** and **GENLOCK** buttons to restart the instrument in Factory mode.
4. Set the genlock source of the sync pulse generator as follows:
 - a. Press the **GENLOCK** button to display the Genlock menu.
 - b. Press the up (\blacktriangle) or down (\blacktriangledown) arrow button to select **GENLOCK SOURCE**.
 - c. Press the left (\blacktriangleleft) or right (\blacktriangleright) arrow button to select **CW 10 MHz**.
 - d. Press the **ENTER** button.
5. Press the **SYSTEM** button to display the System menu.

6. Press the up (▲) or down (▼) arrow button to select **CALIBRATION**.
7. Press the **ENTER** button.
8. Press the up (▲) or down (▼) arrow button to select **FREQ CAL**.
9. Press the **ENTER** button.

This completes the master clock frequency adjustment procedures.



Maintenance

Maintenance

This section contains the information needed to do periodic and corrective maintenance on the sync pulse generator. The following subsections are included:

- *Preparation* – Introduction plus general information on preventing damage to internal modules when doing maintenance.
- *Inspection and Cleaning* – Information and procedures for inspecting the sync pulse generator and cleaning its external and internal modules.
- *Removal and Installation Procedures* – Procedures for the removal of defective modules and replacement of new or repaired modules.
- *Troubleshooting* – Information for isolating and troubleshooting failed modules. Included are instructions for operating the sync pulse generator's internal diagnostic routines and troubleshooting tree.

Related Maintenance Procedures

The following sections contain information and procedures related to maintenance.

- Section 2, *Operating Information*, covers instructions useful when operating the sync pulse generator in order to troubleshoot it.
- Section 3, *Theory of Operation*, contains a circuit description at the module or block level.
- Section 4, *Performance Verification*, contains procedures that may be useful in isolating problems to modules by testing the instrument performance.
- Section 5, *Adjustment Procedure*, addresses after repair adjustment and the interval between periodic adjustments. It contains a procedure for adjusting the master clock frequency of the sync pulse generator.
- Section 9, *Diagrams*, contains a block diagram using individual modules as blocks and an interconnect diagram showing connections between the modules.
- Section 10, *Mechanical Parts List*, lists all field replaceable modules by part number.

Preparation

Before servicing this product, read the *General Safety Summary*, *Service Safety Summary*, and *Introduction* at the front of the manual.

This system contains electrical components that are susceptible to damage from static discharge. Observe the standard precautions to avoid damaging static-sensitive devices.



CAUTION. *To prevent damage from static discharge, service the product only in a static-free environment. Observe standard handling precautions for static-sensitive devices while maintaining this product. Always wear a grounded wrist strap, grounded foot strap, and static resistant apparel.*

Inspection and Cleaning

Inspection and Cleaning describes how to inspect for dirt and damage. It also describes how to clean the exterior and interior of the sync pulse generator. Inspection and cleaning are done as preventive maintenance. Preventive maintenance, when done regularly, may prevent sync pulse generator malfunction and enhance its reliability.

Preventive maintenance consists of visually inspecting and cleaning the sync pulse generator and using general care when operating it.

How often preventive maintenance should be performed depends on the severity of the environment in which the sync pulse generator is used. A proper time to perform preventive maintenance is just before sync pulse generator adjustment.

General Care

The top cover helps keep dust out of the sync pulse generator, and is needed to meet EMI and cooling requirements. The top cover should be in place when operating the sync pulse generator.

Inspection and Cleaning Procedures

Inspect and clean the sync pulse generator as often as operating conditions require. The collection of dirt on components inside can cause them to overheat and breakdown. (Dirt acts like an insulating blanket, preventing efficient heat dissipation.) Dirt also provides an electrical conduction path that could cause a sync pulse generator failure, especially under high-humidity conditions.



CAUTION. *Avoid the use of chemical cleaning agents that might damage the plastic used in this sync pulse generator. Use only deionized water when cleaning the menu buttons or front -panel buttons. Use an ethyl alcohol solution as a cleaner and rinse with deionized water.*

Inspection-Exterior. Inspect the outside of the sync pulse generator for damage, wear, and missing parts, using Table 6-1 as a guide. A sync pulse generator that appears to have been dropped or otherwise abused should be checked thoroughly to verify correct operation and performance. Immediately repair defects that could cause personal injury or lead to further damage to the sync pulse generator.

Table 6-1: External inspection check list

Item	Inspect for	Repair action
Cabinet, front panel, and cover	Cracks, scratches, deformations, damaged hardware or gaskets.	Repair or replace defective modules.
Front-panel buttons	Missing or damaged buttons.	Repair or replace missing or defective buttons.
Connectors	Broken shells, cracked insulation, and deformed contacts. Dirt in connectors.	Repair or replace defective modules. Clear or wash out dirt.
Accessories	Missing or damaged items.	Replace damaged or missing items.

Cleaning Procedure – Exterior. To clean the sync pulse generator exterior, perform the following steps.

1. Remove loose dust on the outside of the sync pulse generator with a lint free cloth.
2. Remove remaining dirt with a lint free cloth dampened in a general purpose detergent-and-water solutions. Do not use abrasive cleaners.
3. Clean the LCD filter with a lint-free cloth dampened with a gentle purpose detergent-and-water solution.



CAUTION. To prevent getting moisture inside the sync pulse generator during external cleaning, use only enough liquid to dampen the cloth or applicator.

Inspection – Interior. To access the inside of the sync pulse generator for inspection and cleaning, refer to the *Removal and Installation Procedures* in this section.

Inspect the internal portions of the sync pulse generator for damage and wear, using Table 6-2 as a guide. Defects found should be repaired immediately.



CAUTION. To prevent damage from electrical arcing, ensure that circuit boards and components are dry before applying power to the sync pulse generator.

Table 6-2: Internal inspection check list

Item	Inspect for	Repair action
Circuit boards	Loose, broken, or corroded solder connections. Burned circuit board. Burned, broken, or cracked circuit-run plating.	Remove failed module and replace with a fresh module.
Resistors	Burned, cracked, broken, or blistered condition.	Remove failed module and replace with a fresh module.
Solder connections	Cold solder or rosin joints.	Resolder joint and clean with isopropyl alcohol.
Capacitors	Damaged or leaking cases. Corroded solder on leads or terminals.	Remove damaged module and replace with a fresh module from the factory.
Semiconductors	Loosely inserted in sockets. Distorted pins.	Firmly seat loose semiconductors. Remove devices that have distorted pins. Carefully straighten pins (as required to fit the socket), using long-nose pliers, and reinsert firmly. Ensure that straightening action does not crack pins, causing them to break off.
Wiring and cables	Loose plugs or connectors. Burned, broken, or frayed wiring.	Firmly seat connectors. Repair or replace modules with defective wires or cables.
Chassis	Dents, deformations, and damaged hardware.	Straighten, repair, or replace defective hardware.

Cleaning – Interior. Examine the interior of the sync pulse generator for dust build up. If the interior needs cleaning, use low-velocity, dry air to blow away dust or lint. If air alone does not remove all of the dust and lint, use a soft brush to complete the task. Be extremely careful not to disturb components on the modules during cleaning.

Lubrication. There is no periodic lubrication required for the sync pulse generator.

Removal and Installation Procedures

This subsection contains procedures for removal and installation of almost all mechanical and electrical modules. Any electrical or mechanical module, assembly, or part listed in Section 10 of this manual is a module.

Preparation



WARNING. Before performing this or any other procedure in this manual, read the General Safety Summary and Service Safety Summary found at the beginning of this manual. Also, to prevent possible injury to service personnel or damage to the sync pulse generator's components, read *Installation in Section 2*, and *Preparation on page 6-2*.

This subsection contains the following items:

- Preparatory information that you need to properly perform the procedures that follow.
- List of tools required to remove and disassemble all modules.
- Four module locator diagrams for finding the SPG600 external modules (see Figure 6-2), SPG600 internal modules (see Figure 6-3), SPG300 external modules (see Figure 6-4), and SPG300 internal modules (see Figure 6-5), in the sync pulse generators.
- Procedures for removal and reinstallation of the electrical and mechanical modules.
- A disassembly procedure for removal of all the major modules from the sync pulse generator at one time and for reassembly of those modules into the sync pulse generator. Such a complete disassembly is normally only done when completely cleaning the sync pulse generator (instructions for doing the actual cleaning are found under *Inspection and Cleaning* at the beginning of this section).
- Module disassembly procedures.



WARNING. Before performing any procedure in this subsection, disconnect the power cord from the line voltage source. Failure to do so could cause serious injury or death.

List of Module Section 10 lists all modules.

General Instructions Read these general instructions before removing a module.

First read over the *Summary of Procedures* that follows to understand how the procedures are grouped. Then read *Equipment Required* for a list of the tools needed to remove and install modules in the sync pulse generator.

If you are removing a module for service, begin by performing the *Access Procedure* (page 6-12). By following the instructions in that procedure, you remove the module to be serviced while removing the minimum number of additional modules.

Summary of Procedures The procedures are described in the order in which they appear in this section. In addition, you can look up any procedure for removal and reinstallation of any module in the *Table of Contents* of this manual.

- The *Access Procedure* on page 6-12 first directs you to the procedure(s) (if any) that are required to access the module to be serviced, then it directs you to the procedure to remove that module.

Table 6-1: Summary of procedures

Procedure	Module	Page
SPG600		
Procedures for SPG600 External Modules	<ul style="list-style-type: none"> ■ Top Cover ■ Front-panel assembly ■ RFI filter 	6-13
Procedures for SPG600 Internal Modules	<ul style="list-style-type: none"> ■ A30 Analog board (Option 02 only) ■ A40 SDI board (Option 03 only) ■ A10 Main board ■ Power supply module 	6-17
SPG300		
Procedures for SPG300 External Modules	<ul style="list-style-type: none"> ■ Top Cover ■ Front-panel assembly ■ RFI filter ■ GPI connector 	6-23
Procedures for SPG300 Internal Modules	<ul style="list-style-type: none"> ■ A60 Analog board ■ A50 Main board ■ Power supply module 	6-27

Equipment Required. Most modules in the sync pulse generator can be removed with a screwdriver handle mounted with a #2 Phillips tip. *Use this tool whenever a screwdriver is specified in that step.* All equipment required to remove and reinstall each module is listed in the first step of its procedure.

Table 6-2: Tools required for module removal

Item No.	Name	Description
1	Screwdriver handle	Accepts Phillips-driver bits
2	#1 Phillips tip	Phillips-driver bit for #1 size screw heads
3	#2 Phillips tip	Phillips-driver bit for #2 size screw heads
4	5 mm Nut Driver	Socket or driver for 5 mm nuts

Instrument Orientation

In this manual, procedures refer to “front,” “back,” “top,” etc. of the sync pulse generator. Figure 6-1 shows how the sides are referenced.

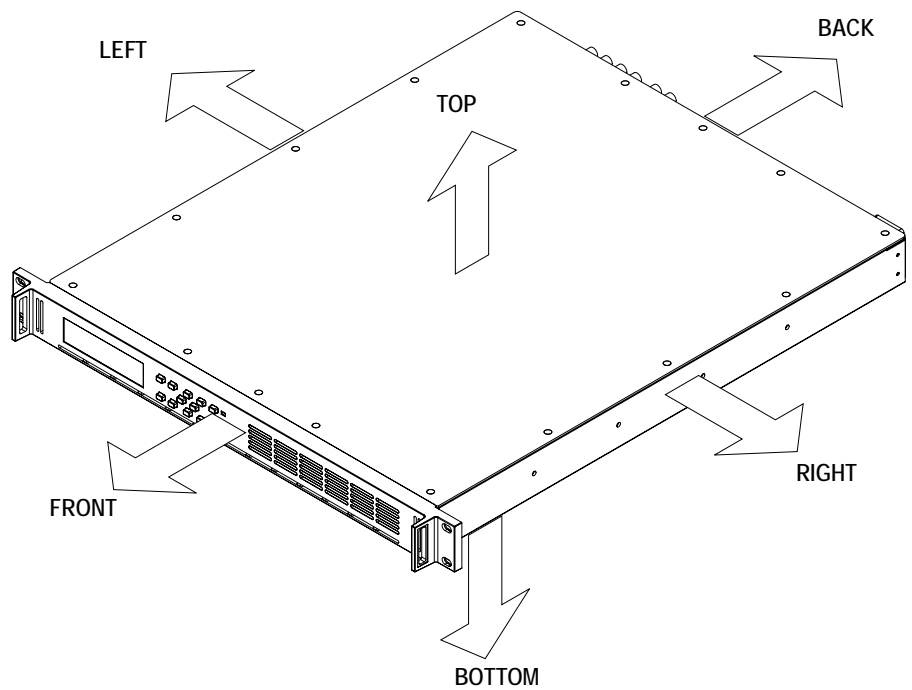

Figure 6-1: Instrument orientation (SPG600)

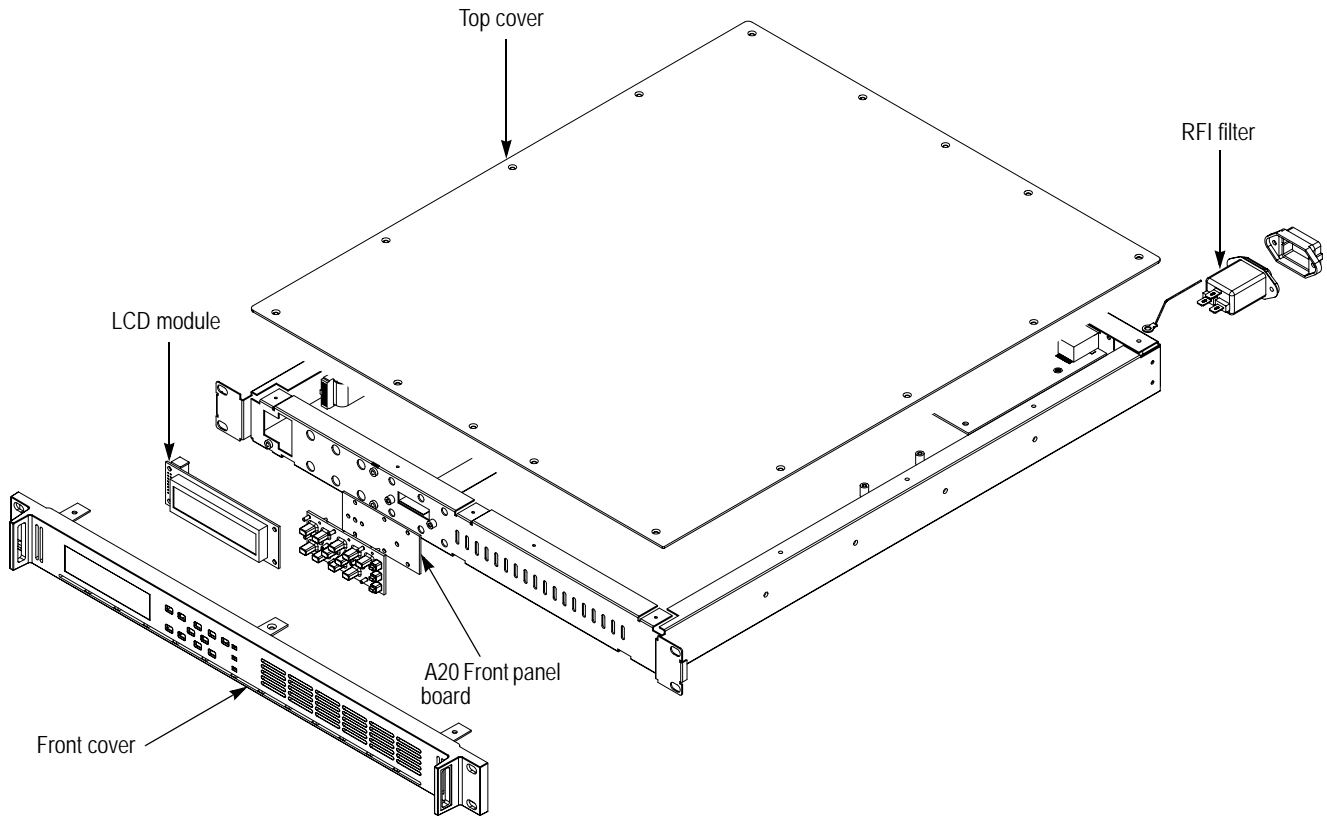

Figure 6-2: SPG600 external modules

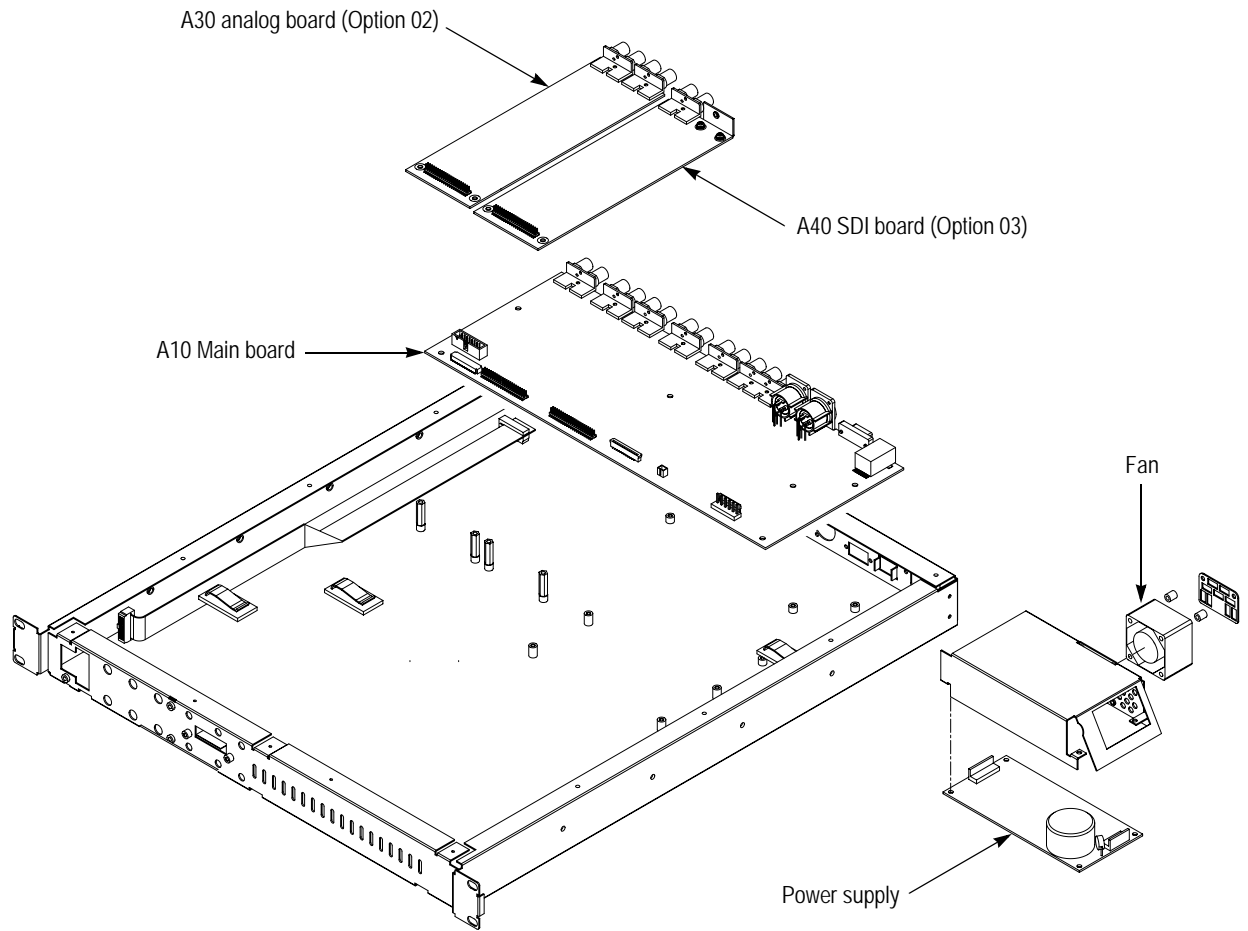

Figure 6-3: SPG600 internal modules

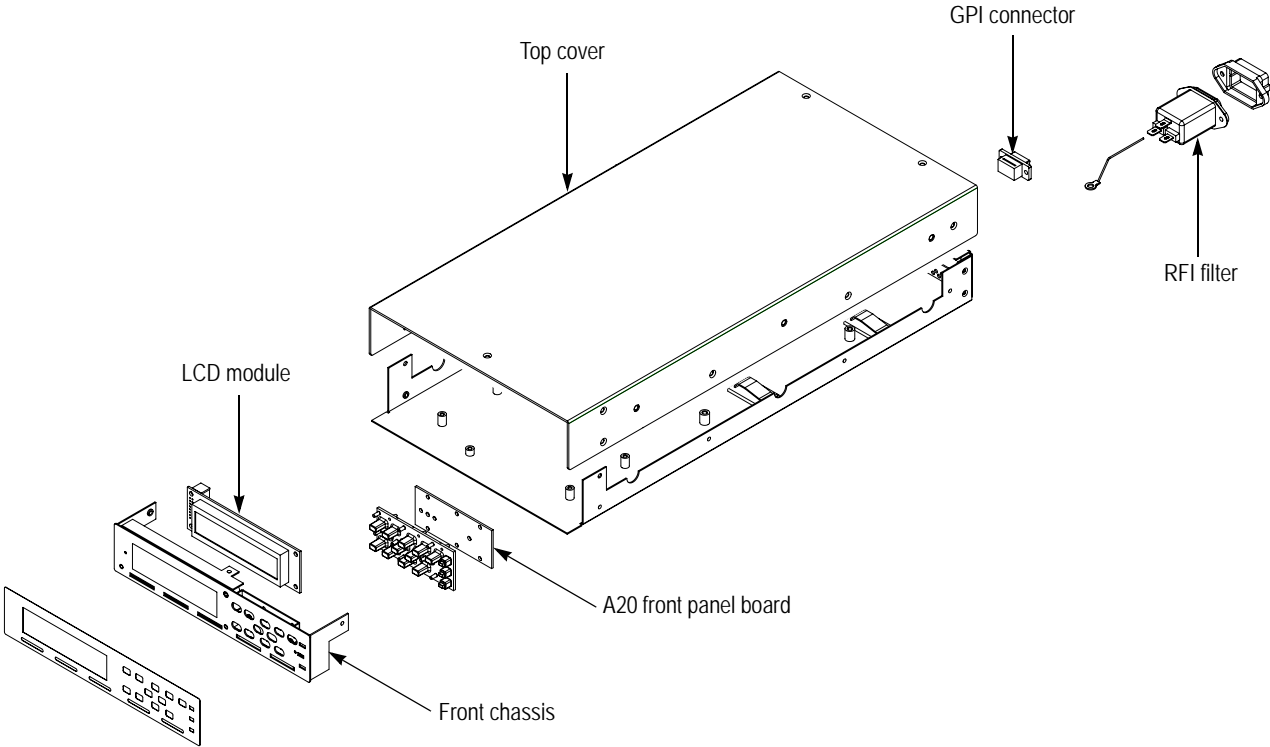

Figure 6-4: SPG300 external modules

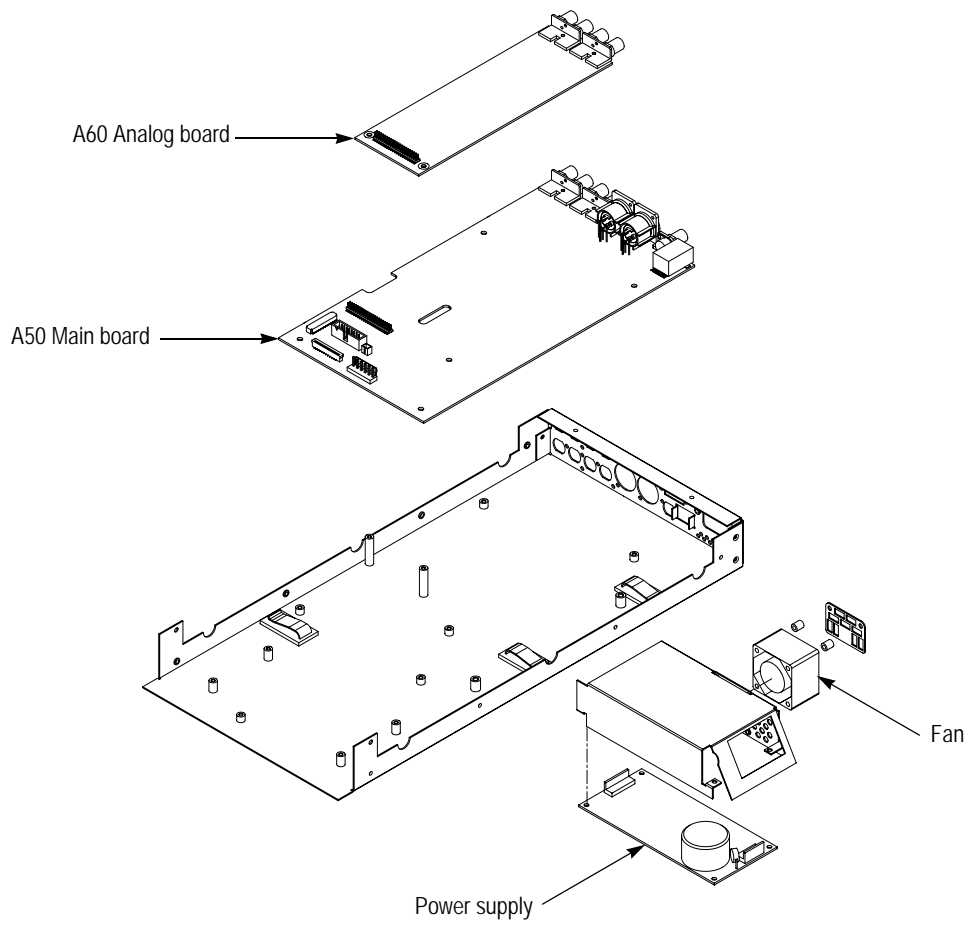

Figure 6-5: SPG300 internal modules

Access Procedure

When you have identified the module to be removed for service, read *General Instructions* found on page 6-6. Then use the flowchart in Figure 6-6 to determine which procedures to use for removing the module. The removal procedures end with installation instructions.

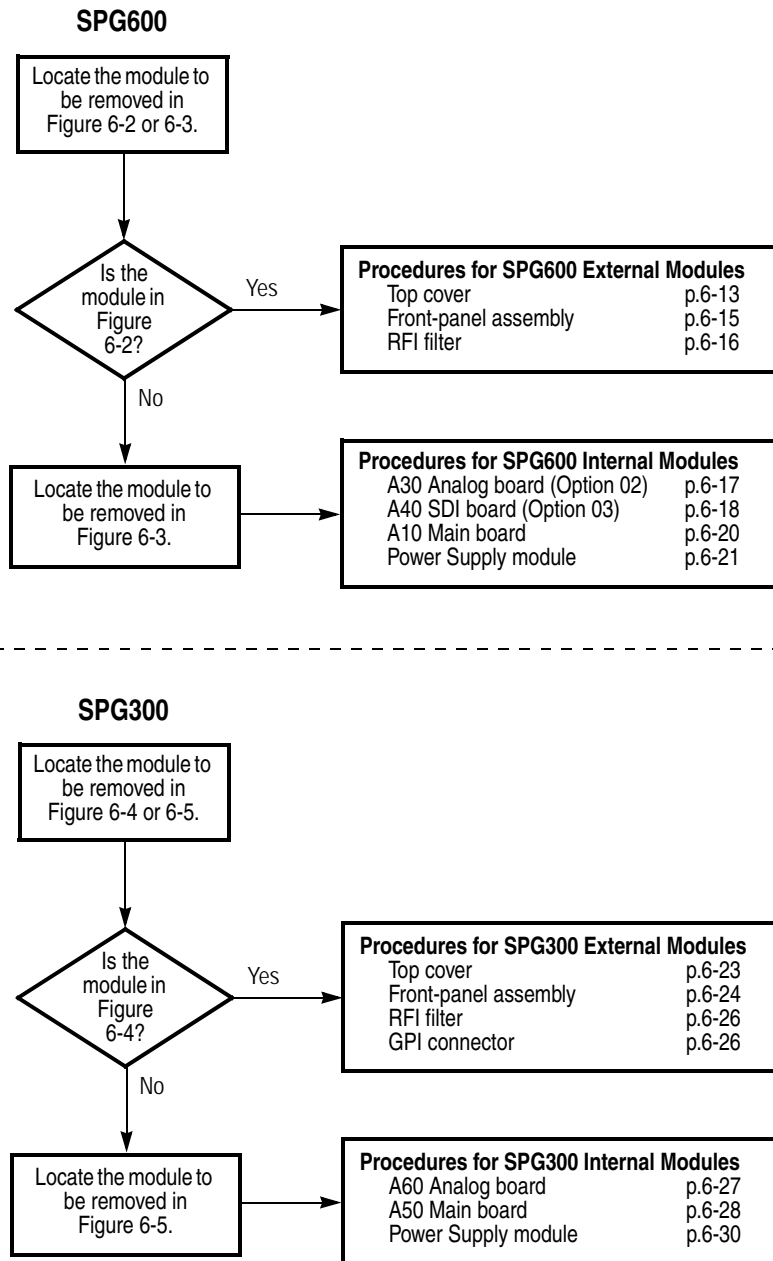

Figure 6-6: Guide to removal procedures

Procedures for SPG600 External Modules

Perform the *Access Procedure* (page 6-12) before doing any procedure in this group. This group contains the following procedures:

- *Top cover*
- *Front-panel assembly*
- *RFI filter*

Top Cover

1. *Locate module to be removed:* Locate the top cover in the location diagram *SPG600 External Modules*, Figure 6-2, on page 6-8.
2. *Orient the instrument:* Set the SPG600 so its bottom is down on the work surface and its rear is facing you.
3. *Remove the top cover:* See Figure 6-7.
 - a. Use a screwdriver with a #2 phillips tip to remove the sixteen screws securing the top cover to the chassis.
 - b. Lift the top cover off the chassis.
4. *Reinstall the top cover:* Perform step 3 in reverse order to reinstall the top cover.

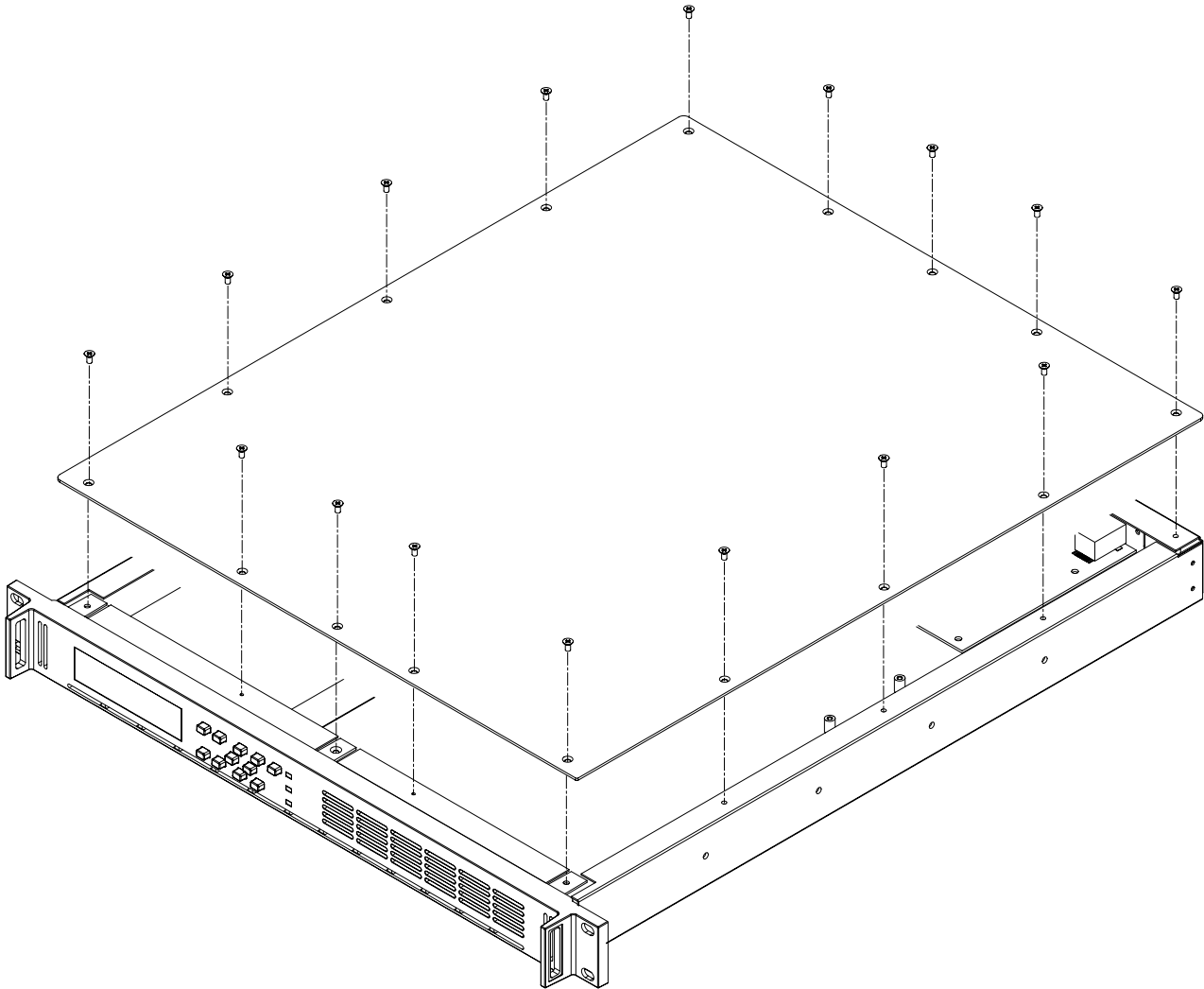

Figure 6-7: Top cover removal (SPG600)

Front-Panel Assembly

1. *Locate module to be removed:* Locate the front-panel assembly in the locator diagram *SPG600 External modules*, Figure 6-2, on page 6-8.
2. *Orient instrument:* Set the SPG600 so its bottom is down on the work surface and its front is facing you.
3. *Remove the front cover:* See Figure 6-8.
 - a. Push and release the three snaps at the bottom of the front cover using a flat-bladed screwdriver.
 - b. Grasp the front cover and pull it forward.
4. *Remove the LCD module:* See Figure 6-8.
 - a. Use a screwdriver with a #2 Phillips tip to remove the four screws securing the LCD module to the chassis.
 - b. Unplug the cable from the A10 Main board.
5. *Remove the A20 front-panel board:* See Figure 6-8.
 - a. Use a screwdriver with a #2 Phillips tip to remove the two screws securing the LCD module to the chassis.
 - b. Unplug the cable from the A10 Main board.
6. *Reinstallation:* Perform steps 3 through 5 in reverse order to reinstall the front-panel assembly.

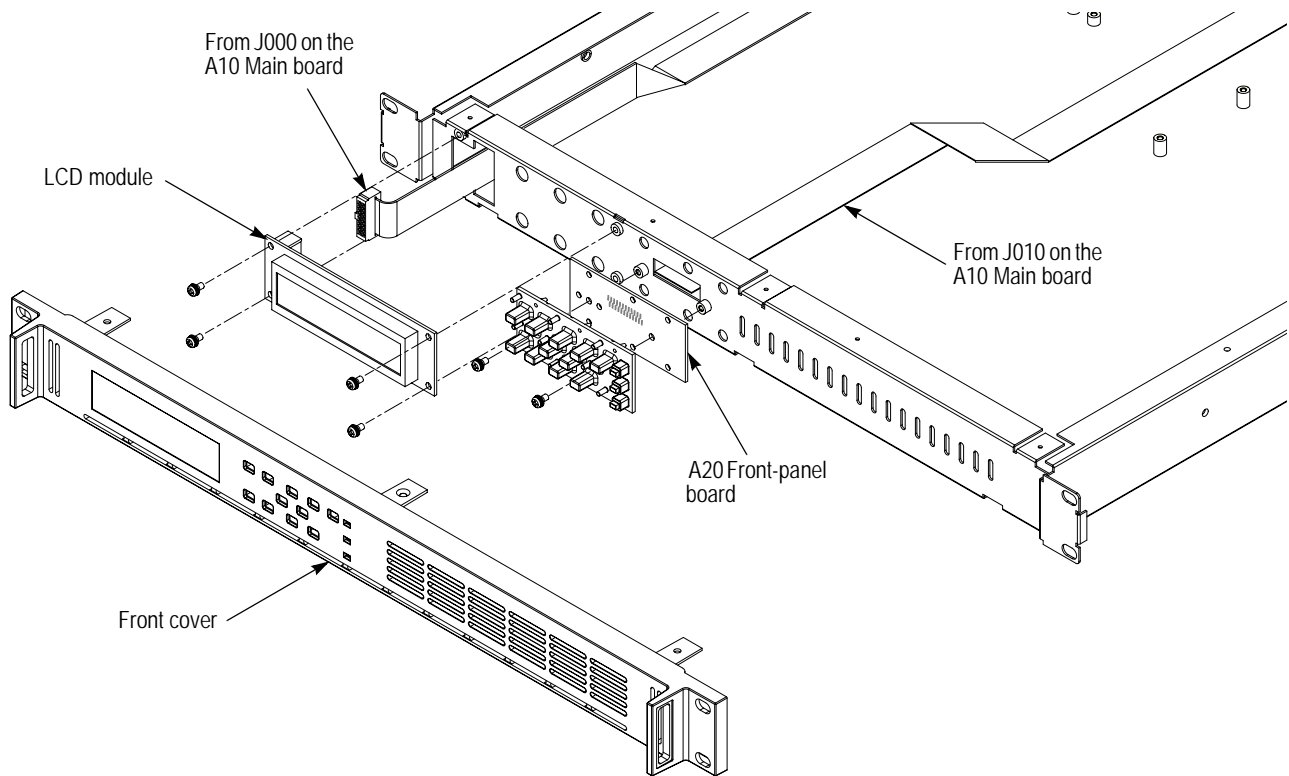

Figure 6-8: Front-panel assembly removal (SPG600)

- RFI Filter**
1. *Locate module to be removed:* Locate the RFI filter in the locator diagram *SPG600 External modules*, Figure 6-2, on page 6-8.
 2. *Remove the RFI filter:*
 - a. Unplug the cable from the A10 Main board.
 - b. Use a screwdriver with a #2 Phillips tip to remove the screw securing the ground lead to the chassis.
 - c. Use a screwdriver with a #2 Phillips tip to remove the two screws securing the RFI filter to the chassis.
 - d. Pull out the RFI filter from the chassis.
 3. *Reinstallation:* Perform step 2 in reverse order to reinstall the RFI filter.

Procedure for SPG600 Internal Modules

Perform the *Access Procedure* (on page 6-12) before doing any procedure in this group. The procedures are:

- *A30 Analog board (Option 02 only)*
- *A40 SDI board (Option 03 only)*
- *A10 Main board*
- *Power supply module*

A30 Analog Board (Option 02 Only)

1. *Locate module to be removed:* Locate the A30 Analog board in the locator diagram *SPG600 Internal modules*, Figure 6-3, on page 6-9.
2. *Orient the instrument:* Set the SPG600 so its bottom is down on the work surface and its right side is facing you.
3. *Remove the A30 Analog board:* See Figure 6-9.
 - a. Unplug the cable from the A10 Main board at J1.
 - b. Use a screwdriver with #1 Phillips tip to remove the two screws securing the A30 Analog board to the rear of the chassis.
 - c. Use a screwdriver with #2 Phillips tip to remove the two screws securing the A30 Analog board to the bottom of the chassis.
 - d. Lift the board up and away from the chassis to complete the removal.
4. *Reinstallation:* Perform step 3 in reverse order to reinstall the A30 Analog board.

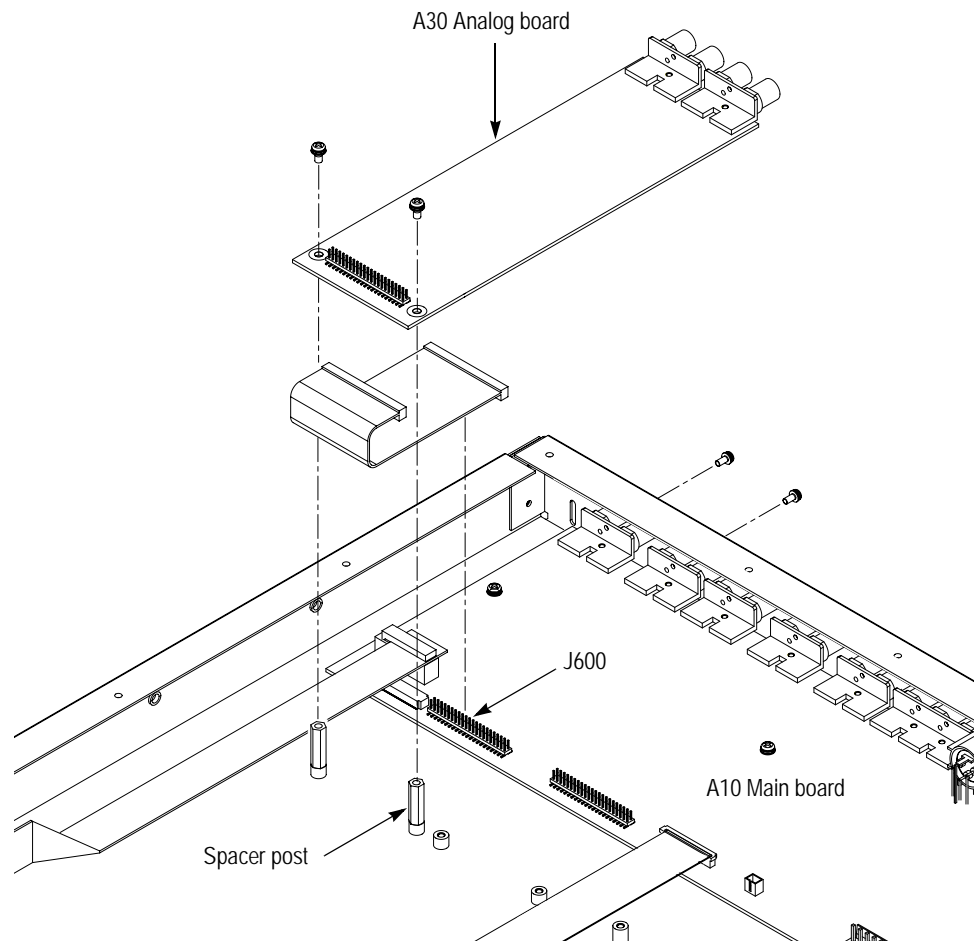

Figure 6-9: A30 Analog board removal

A40 SDI Board (Option 03 Only)

1. *Locate module to be removed:* Locate the A40 SDI board in the locator diagram *SPG600 Internal modules*, Figure 6-3, on page 6-9.
2. *Orient the instrument:* Set the SPG600 so its bottom is down on the work surface and its right side is facing you.
3. *Remove the A40 SDI board:* See Figure 6-10.
 - a. Unplug the cable from the A10 Main board at J1.
 - b. Use a screwdriver with #1 Phillips tip to remove the two screws securing the A40 SDI board to the rear of the chassis.

- c. Use a screwdriver with #2 Phillips tip to remove the two screws securing the A40 SDI board to the bottom of the chassis.
 - d. Lift the board up and away from the chassis to complete the removal.
4. *Reinstallation:* Perform step 3 in reverse order to reinstall the A40 SDI board.

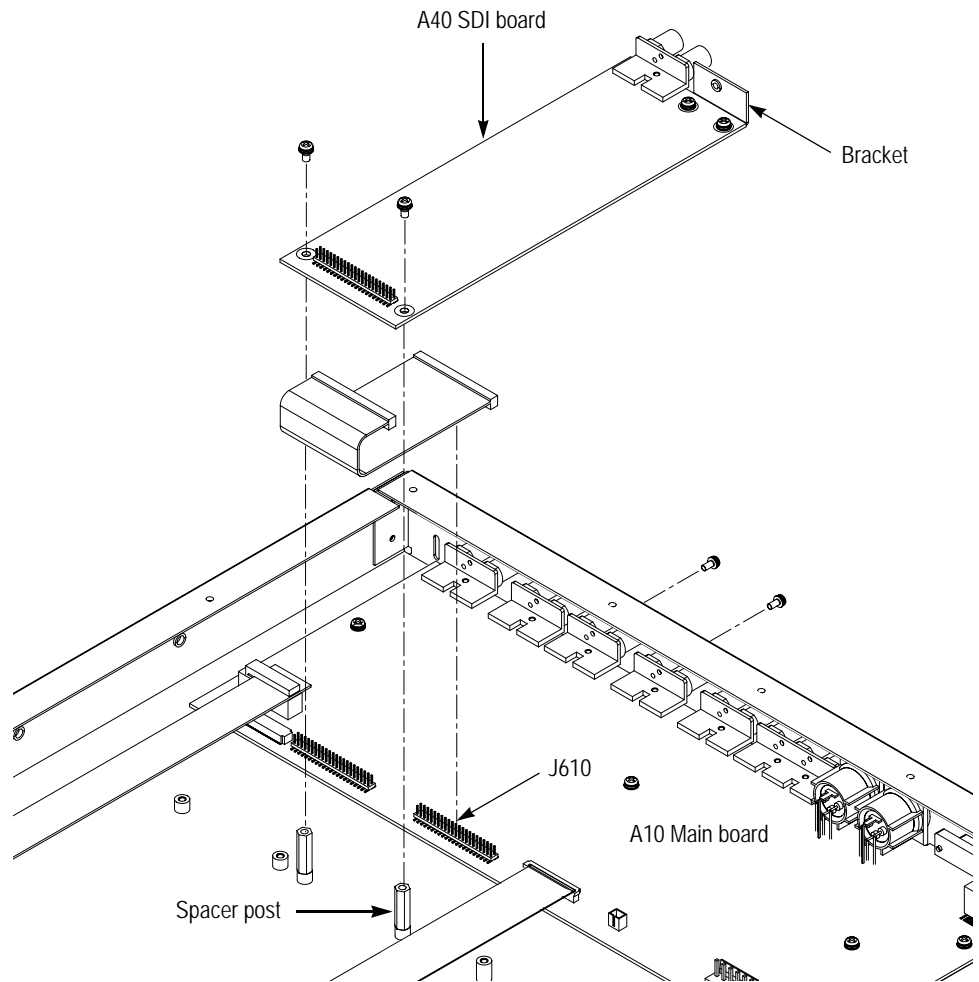

Figure 6-10: A40 SDI board removal

A10 Main Board

1. *Locate module to be removed:* Locate the A10 Main board in the locator diagram *SPG600 Internal modules*, Figure 6-3, on page 6-9.
2. *Orient the instrument:* Set the SPG600 so its bottom is down on the work surface and its right side is facing you.
3. *Remove the A10 Main board:* See Figure 6-11.
 - a. Unplug these cables:
 - The cable from the LCD module at J000.
 - The cable from the A20 Front-panel board at J010.
 - The cable from the fan at J5.
 - The cable from the power supply at J900.
 - b. Use a screwdriver with a #1 Phillips tip to remove the eleven screws securing the A10 Main board to the rear of the chassis.
 - c. Use a 5 mm size nut driver to remove the two Hex-headed mounting posts securing the GPI connector to the chassis.
 - d. Use a screwdriver with a #2 Phillips tip to remove the six screws securing the A10 Main board to the bottom of the chassis.
4. Lift the board up and away from the chassis to complete the removal.
5. *Reinstallation:* Perform steps 3 and 4 in reverse order to reinstall the A10 Main board.

NOTE. *After you have replaced the A10 Main board, you need to set the instrument serial number, system date and time, and install the option key (Option 01 only). Refer to Setting the Main Board Parameters after Replacement on page 6-33 for detailed information.*

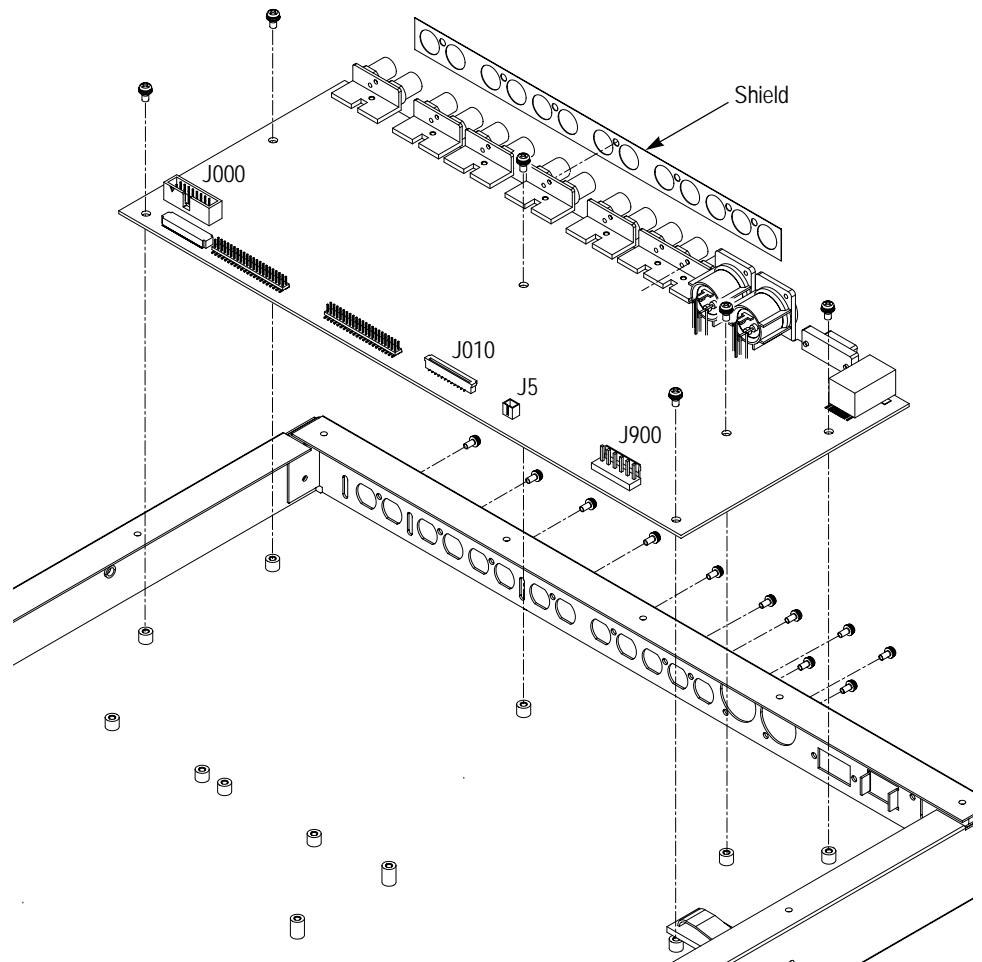

Figure 6-11: A10 Main board removal

Power Supply Module

This procedure describes how to remove these modules:

- Fan
- Power supply

1. *Locate modules to be removed:* Locate the fan and power supply module in the locator diagram *SPG600 Internal modules*, Figure 6-3, on page 6-9.
2. *Orient the instrument:* Set the SPG600 so its bottom is down on the work surface and its right side is facing you.

3. *Remove the fan:* See Figure 6-12.
 - a. Unplug the fan's power cable from J5 on the A10 Main board.
 - b. Use a screwdriver with a #2 Phillips tip to remove the three screws securing the fan to the power supply shield.
 - c. Lift the fan up and away from the shield to complete the removal.
4. *Remove the power supply:* See Figure 6-12.
 - a. Unplug the two cables from the RFI filter.
 - b. Unplug the cable from A10 Main board at J900.
 - c. Use a screwdriver with a #2 Phillips tip to remove the four screws securing the power supply and the shield to the chassis.
 - d. Lift the shield up and away from the chassis.
 - e. Lift the power supply up and away from the chassis.
5. *Reinstallation:* Perform steps 3 and 4 in reverse order to reinstall the power supply module.

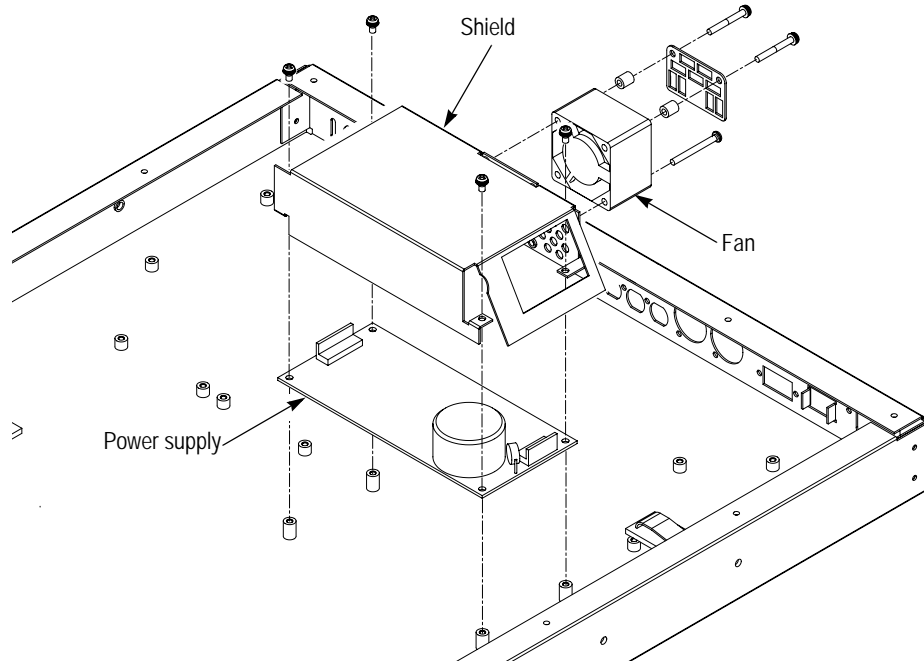

Figure 6-12: Power supply module removal (SPG600)

Procedures for SPG300 External Modules

Perform the *Access Procedure* (page 6-12) before doing any procedure in this group. This group contains the following procedures:

- *Top cover*
- *Front-panel assembly*
- *RFI filter*
- *GPI Connector*

- Top Cover**
1. *Locate module to be removed:* Locate the top cover in the location diagram *SPG300 External Modules*, Figure 6-4, on page 6-10.
 2. *Orient the instrument:* Set the SPG300 so its bottom is down on the work surface and its front is facing you.
 3. *Remove the top cover:* See Figure 6-13.
 - a. Use a screwdriver with a #2 phillips tip to remove the thirteen screws securing the top cover to the chassis.
 - b. Lift it off the chassis.
 4. *Reinstall the top cover:* Perform step 3 in reverse order to reinstall the top cover.

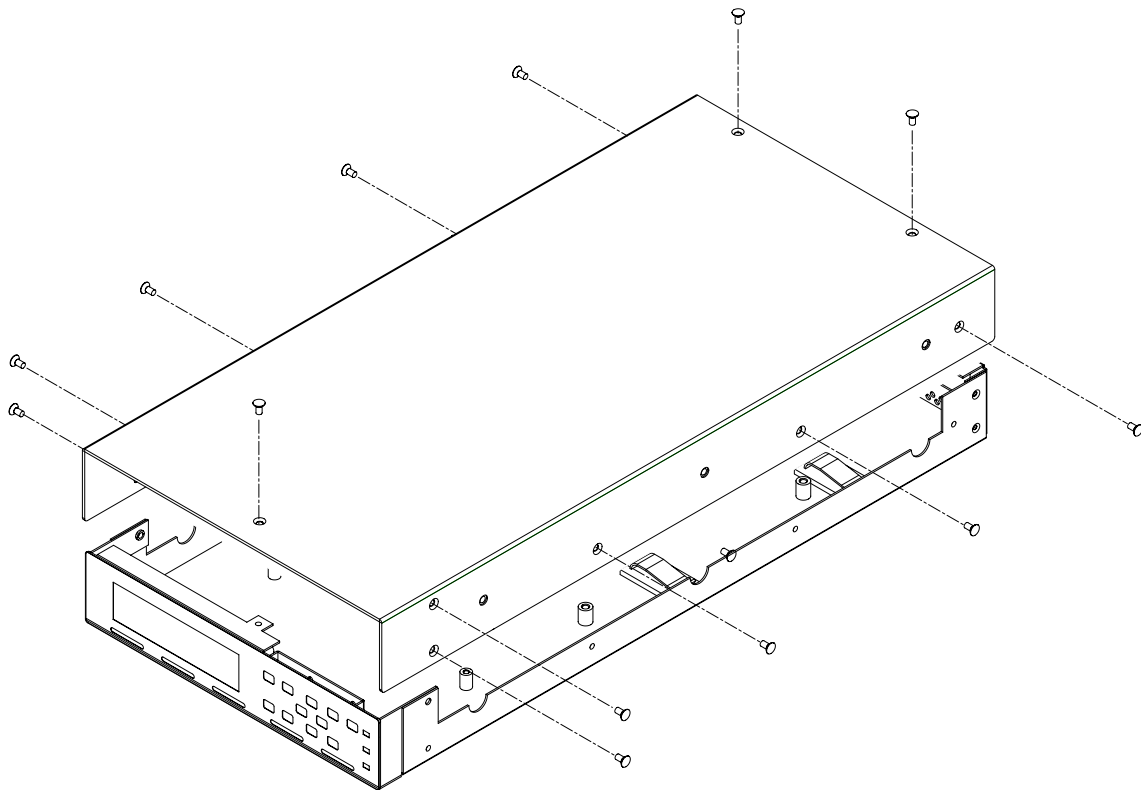

Figure 6-13: Top cover removal (SPG300)

Front-Panel Assembly

1. *Locate module to be removed:* Locate the front-panel assembly in the locator diagram *SPG300 External modules*, Figure 6-4, on page 6-10.
2. *Orient instrument:* Set the SPG300 so its bottom is down on the work surface and its front is facing you.
3. *Remove the front chassis:* See Figure 6-14.
 - a. Use a screwdriver with a #2 Phillips tip to remove the screw securing the front chassis to the main chassis
 - b. Lift it away from the main chassis.
4. *Remove the LCD module:* See Figure 6-14.
 - a. Use a screwdriver with a #2 Phillips tip to remove the four screws securing the LCD module to the front chassis.
 - b. Unplug the cable from the A50 Main board.

5. *Remove the A20 front-panel board:* See Figure 6-14.
 - a. Use a screwdriver with a #2 Phillips tip to remove the two screws securing the A20 front-panel board to the chassis.
 - b. Unplug the cable from the A10 Main board.
6. *Reinstallation:* Perform steps 3 through 5 in reverse order to reinstall the front-panel assembly.

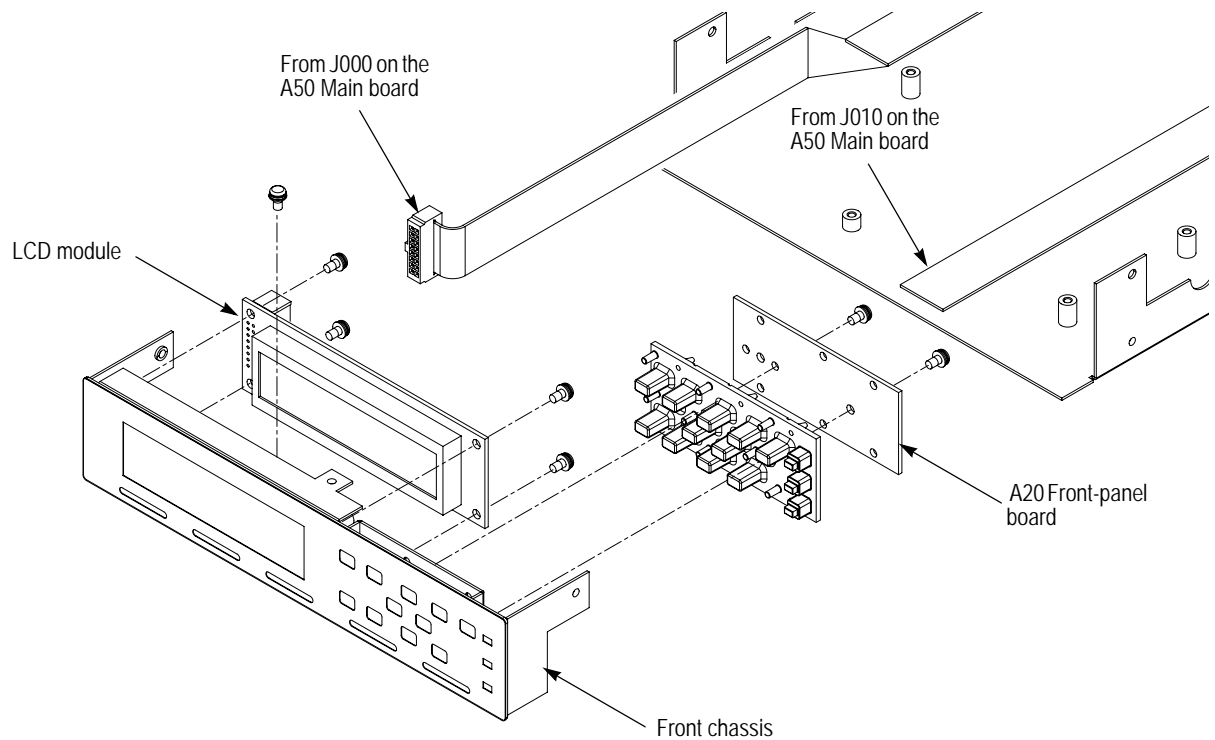

Figure 6-14: Front-panel assembly removal (SPG300)

- RFI Filter**
1. *Locate module to be removed:* Locate the RFI filter in the locator diagram *SPG300 External modules*, Figure 6-4, on page 6-10.
 2. *Remove the RFI filter:*
 - a. Unplug the two cables from the RFI filter.
 - b. Use a screwdriver with a #2 Phillips tip to remove the screw securing the ground lead to the chassis.
 - c. Use a screwdriver with a #2 Phillips tip to remove the two screws securing the RFI filter to the chassis.
 - d. Pull out the RFI filter from the chassis.

Reinstallation: Perform step 2 in reverse order to reinstall the RFI filter.

- GPI Connector**
1. *Locate module to be removed:* Locate the GPI connector in the locator diagram *SPG300 External modules*, Figure 6-4, on page 6-10.
 2. *Remove the GPI connector:*
 - a. Unplug the cable from the A50 Main board.
 - b. Use a 5 mm size nut driver to unscrew the two Hex-headed mounting posts securing the GPI connector to the chassis.
 - c. Pull out the connector away from the chassis.

Reinstallation: Perform step 2 in reverse order to reinstall the GPI connector.

Procedures for SPG300 Internal Modules

Perform the *Access Procedure* (page 6-12) before doing any procedure in this group. This group contains the following procedures:

- *A60 Analog board*
- *A50 Main board*
- *Power supply module*

A60 Analog board

1. *Locate module to be removed:* Locate the A60 analog board in the location diagram *SPG300 Internal Modules*, Figure 6-5, on page 6-11.
2. *Orient the instrument:* Set the SPG300 so its bottom is down on the work surface and its right side is facing you.
3. *Remove the A60 Analog board:* See Figure 6-15.
 - a. Unplug the cable from the A50 Main board at J600.
 - b. Use a screwdriver with #1 Phillips tip to remove the two screws securing the A50 Analog board to the rear of the chassis.
 - c. Use a screwdriver with #2 Phillips tip to remove the two screws securing the A50 Analog board to the bottom of the chassis.
 - d. Lift the board up and away from the chassis to complete the removal.
4. *Reinstallation:* Perform step 3 in reverse order to reinstall the A60 Analog board.

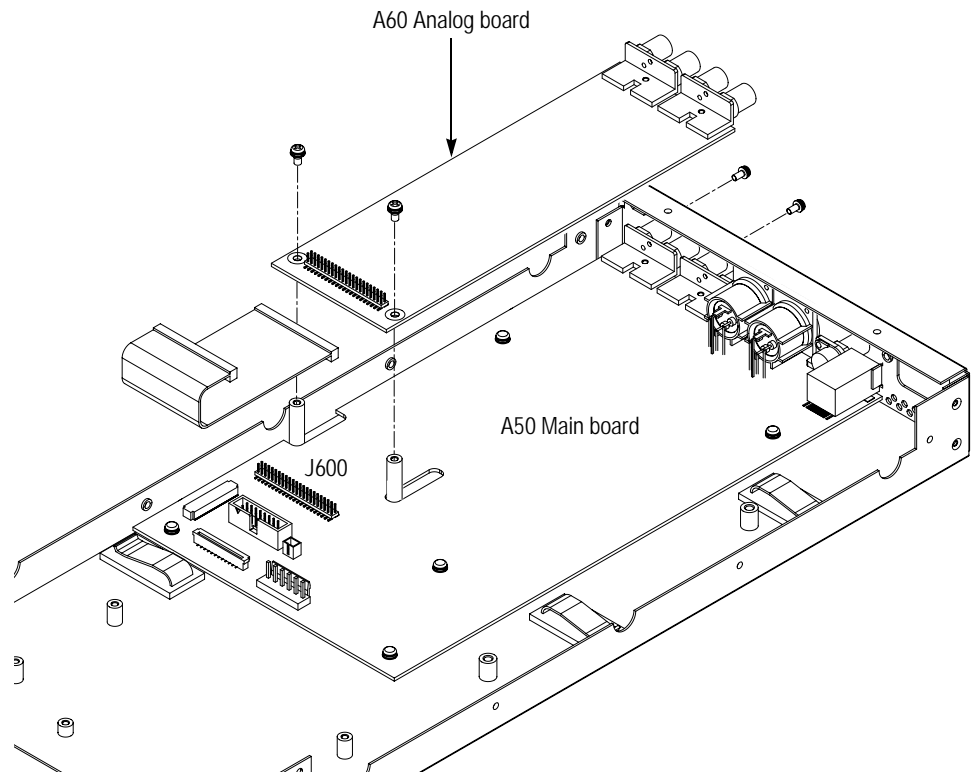

Figure 6-15: A60 Analog board removal

A50 Main Board

1. *Locate module to be removed:* Locate the A50 Main board in the locator diagram *SPG300 Internal modules*, Figure 6-5, on page 6-11.
2. *Orient the instrument:* Set the SPG300 so its bottom is down on the work surface and its right side is facing you.
3. *Remove the A50 Main board:* See Figure 6-16.
 - a. Unplug these cables:
 - The cable from the LCD module at J000.
 - The cable from the A20 Front-panel board at J010.
 - The cable from the fan at J3.
 - The cable from the power supply at J900.
 - The cable from the GPI connector at J100.
 - b. Use a screwdriver with a #1 Phillips tip to remove the seven screws securing the A50 Main board to the rear of the chassis.

- c. Use a screwdriver with a #2 Phillips tip to remove the five screws securing the A50 Main board to the bottom of the chassis.
 4. Lift the board up and away from the chassis to complete the removal.
 5. *Reinstallation:* Perform steps 3 and 4 in reverse order to reinstall the A50 Main board.

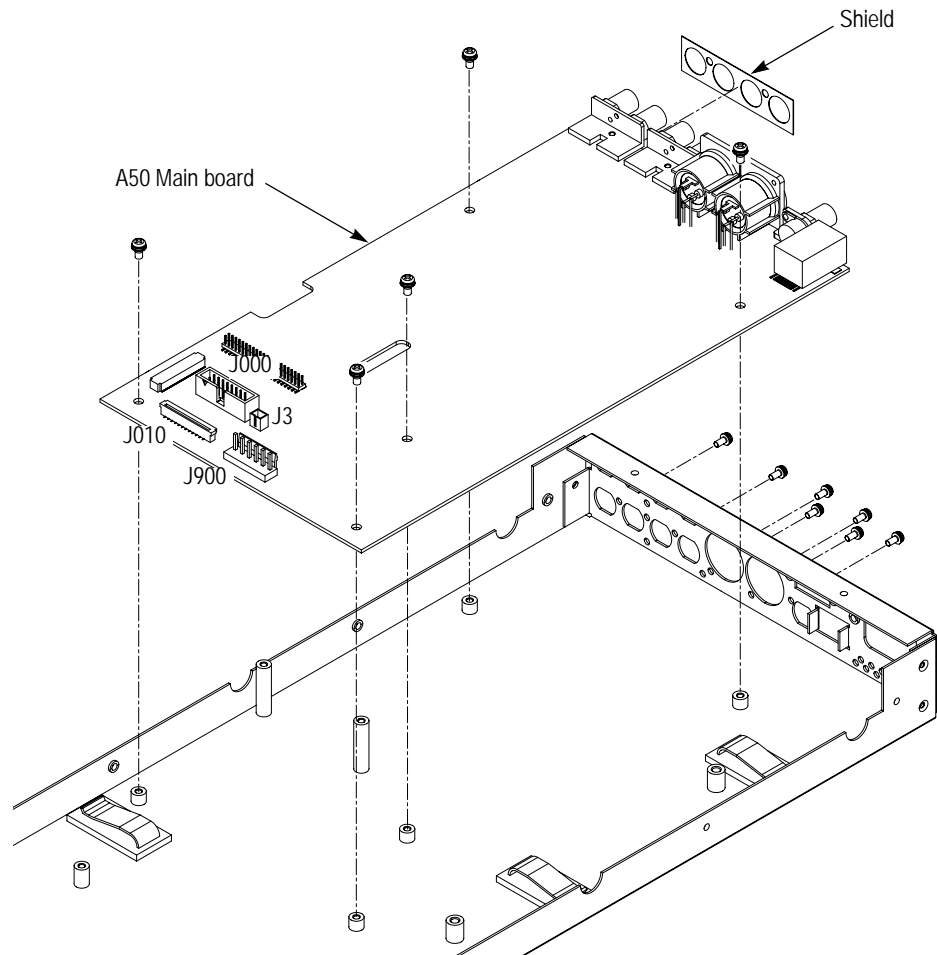

Figure 6-16: A50 Main board removal

NOTE. After you have replaced the A50 Main board, you need to set the instrument serial number, system date and time, and install the option key (Option 01 only). Refer to Setting the Main Board Parameters after Replacement on page 6-33 for detailed information.

Power Supply Module

This procedure describes how to remove these modules:

- *Fan*
 - *Power supply*
1. *Locate modules to be removed:* Locate the fan and power supply module in the locator diagram *SPG300 Internal modules*, Figure 6-5, on page 6-11.
 2. *Orient the instrument:* Set the SPG300 so its bottom is down on the work surface and its right side is facing you.
 3. *Remove the fan:* See Figure 6-17.
 - a. Unplug the fan's power cable from J3 on the A50 Main board.
 - b. Use a screwdriver with a #2 Phillips tip to remove the three screws securing the fan to the power supply shield.
 - c. Lift the fan up and away from the shield to complete the removal
 4. *Remove the power supply:* See Figure 6-17.
 - a. Unplug the two cables from the RFI filter.
 - b. Unplug the cable from A50 Main board at J900.
 - c. Use a screwdriver with a #2 Phillips tip to remove the four screws securing the power supply and the shield to the chassis.
 - d. Lift the shield up and away from the chassis.
 - e. Lift the power supply up and away from the chassis.
 5. *Reinstallation:* Perform steps 3 and 4 in reverse order to reinstall the power supply module.

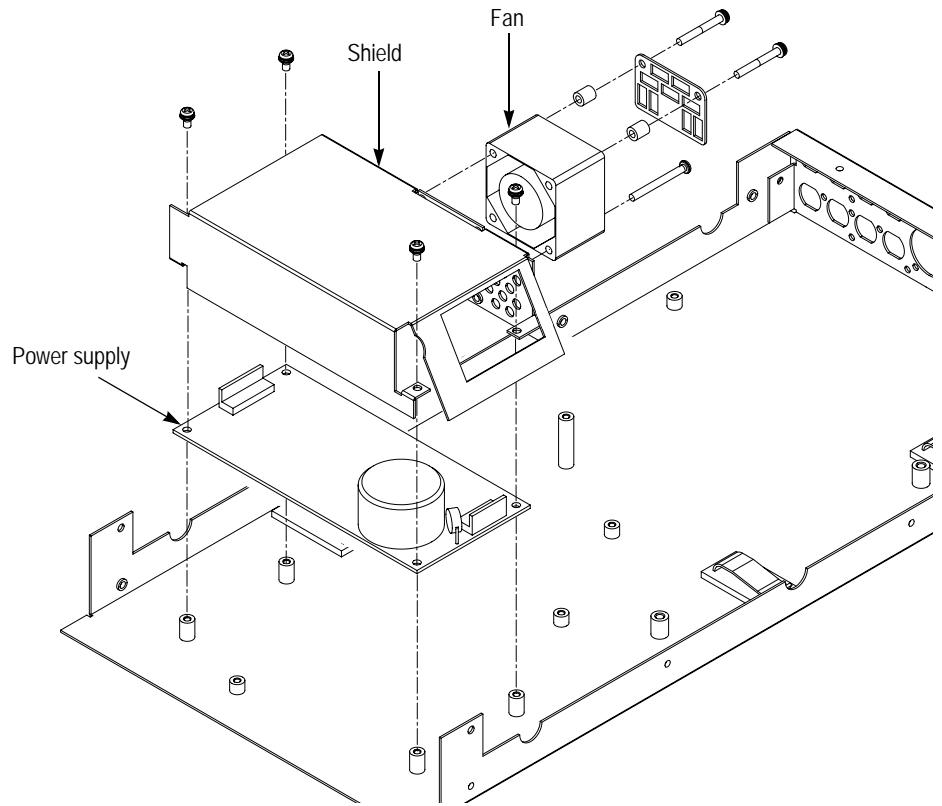

Figure 6-17: Power supply module removal (SPG300)

Setting Main Board Parameters after Replacement

After you have replaced the Main board, you need to set the instrument serial number, system date and time, and install the option key (Option 01 only). This section describes these procedures.

Setting the Instrument Serial Number

Perform the following procedure to set the instrument serial number:

NOTE. The serial number label is placed on the right side of the chassis for the SPG600, at the bottom of the chassis for the SPG300. The serial number is expressed as J010xxxx or C010xxxx.

1. Power on (plug in) the instrument with the **PANEL ENABLE** button pressed. This starts up the instrument in Factory mode.
2. Press the **SYSTEM** button to display the System menu.
3. Press the up (▲) or down (▼) arrow button to select **SYSTEM PARAMETER**.
4. Press the left (◀) or right (▶) arrow button to select **Setup**.
5. Press the **ENTER** button to display the System setup submenu.
6. Press the up (▲) or down (▼) arrow button to select **S/N**.
7. Enter the serial number using the following steps:
 - a. Press the **ENTER** button to enable the text entering mode. The underscore character (_) appears at the far left of the second line.
 - b. Press the up (▲) or down (▼) arrow button to select a character.
 - c. Press the left (◀) or right (▶) arrow button to move the underscore character and then use the up (▲) or down (▼) arrow button to select the character.
 - d. Repeat step c until all of the alphanumeric number is entered.
 - e. Press the **ENTER** button to end the text entering process.

Installing the Option Key (Option 01 Only)

Perform the following procedure to install the option key for the fine timing adjustment feature (Option 01).

1. Press the up (▲) or down (▼) arrow button to select **OPTION KEY**.
2. Enter the option key using the following steps:
 - a. Press the **ENTER** button to enable the text entering mode. The underscore character (_) appears at the far left of the second line.
 - b. Press the up (▲) or down (▼) arrow button to select a character.
 - c. Press the left (◀) or right (▶) arrow button to move the underscore character and then press the up (▲) or down (▼) arrow button to select the character.
 - d. Repeat step c until all of the alphanumeric number is entered.
 - e. Press the **ENTER** button to end the text entering process.

NOTE. When you make a typing mistake or enter an invalid option key for your instrument, the error message ***BAD OPTION KEY*** appears. If this happens, press the **CANCEL** button and then repeat step 2.

Setting the Date and Time

Perform the following procedure to set the system date and time of the instrument using the remote interface. The system date and time are used for the SNMP error reporting.

Refer to the *SPG600 & SPG300 Sync Pulse Generators User Manual* for detailed information on how to use the remote interface.

1. Connect the instrument to a local area network via Ethernet.
2. Set the network parameters of the instrument. Refer to the *SPG600 & SPG300 Sync Pulse Generators User Manual* for detailed information about the network parameters.
3. Enable Web browser access as follows:
 - a. Press the **SYSTEM** button to display the System menu.
 - b. Press the up (▲) or down (▼) arrow button to select **NETWORK**.
 - c. Press the left (◀) or right (▶) arrow button to select **Setup**.
 - d. Press the **ENTER** button.

- e. Press the up (▲) or down (▼) arrow button to select **WEB INTERFACE**.
 - f. Press the left (◀) or right (▶) arrow button to select **Enable**.
 - g. Press the **ENTER** button.
4. Start your Web browser on your PC and type the network address of the instrument into the URL entry box.
 5. In the Web browser window, click **Launch SPG600/SPG300 Remote User Interface**. The Java applet windows appears.
 6. Select **Date and Time** from the **Utility** pull-down menu to open the Date and Time dialog box.

NOTE. Before you set the date and time of the instrument, be sure to check that your PC's system clock is set correctly.

7. Set the year, month, day, and time.
8. Click the **Apply** button to enable the settings.

Troubleshooting

This section contains information about diagnostics and troubleshooting trees designed to isolate faulty modules in the sync pulse generator.

Diagnostics The sync pulse generator has internal diagnostics that verify memory functionality.



CAUTION. *When you execute the diagnostics, be sure to save the current instrument settings to a preset, and then recall the settings after the diagnostics is completed.*

Perform the following procedures to execute the diagnostics:

1. Power on (plug in) the sync pulse generator with the **PANEL ENABLE** button pressed. This starts up the instrument in Factory mode.
2. Wait until initialization is completed. Check that no error messages appear on the display.
3. Press the **SYSTEM** button to display the System menu.
4. Press the up (▲) or down (▼) arrow button to select **DIAGNOSTICS**.
5. Press the **ENTER** button.
6. Check that the message **PASS, Press CANCEL** is displayed on the display.

If the message **FAIL, Press CANCEL** is displayed, replace the A10 Main board.

Troubleshooting Trees

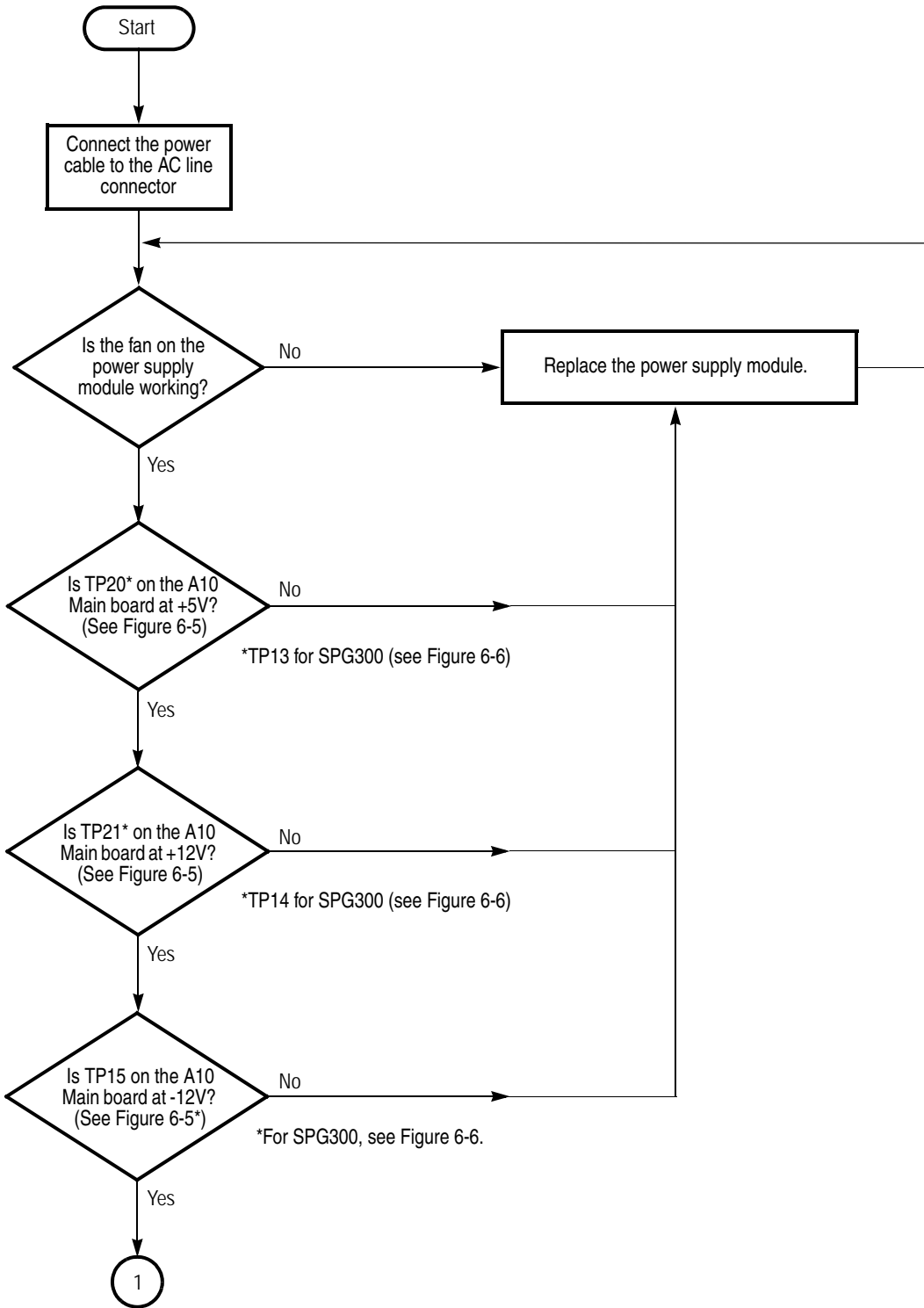

Figure 6-1: Troubleshooting procedure (1)

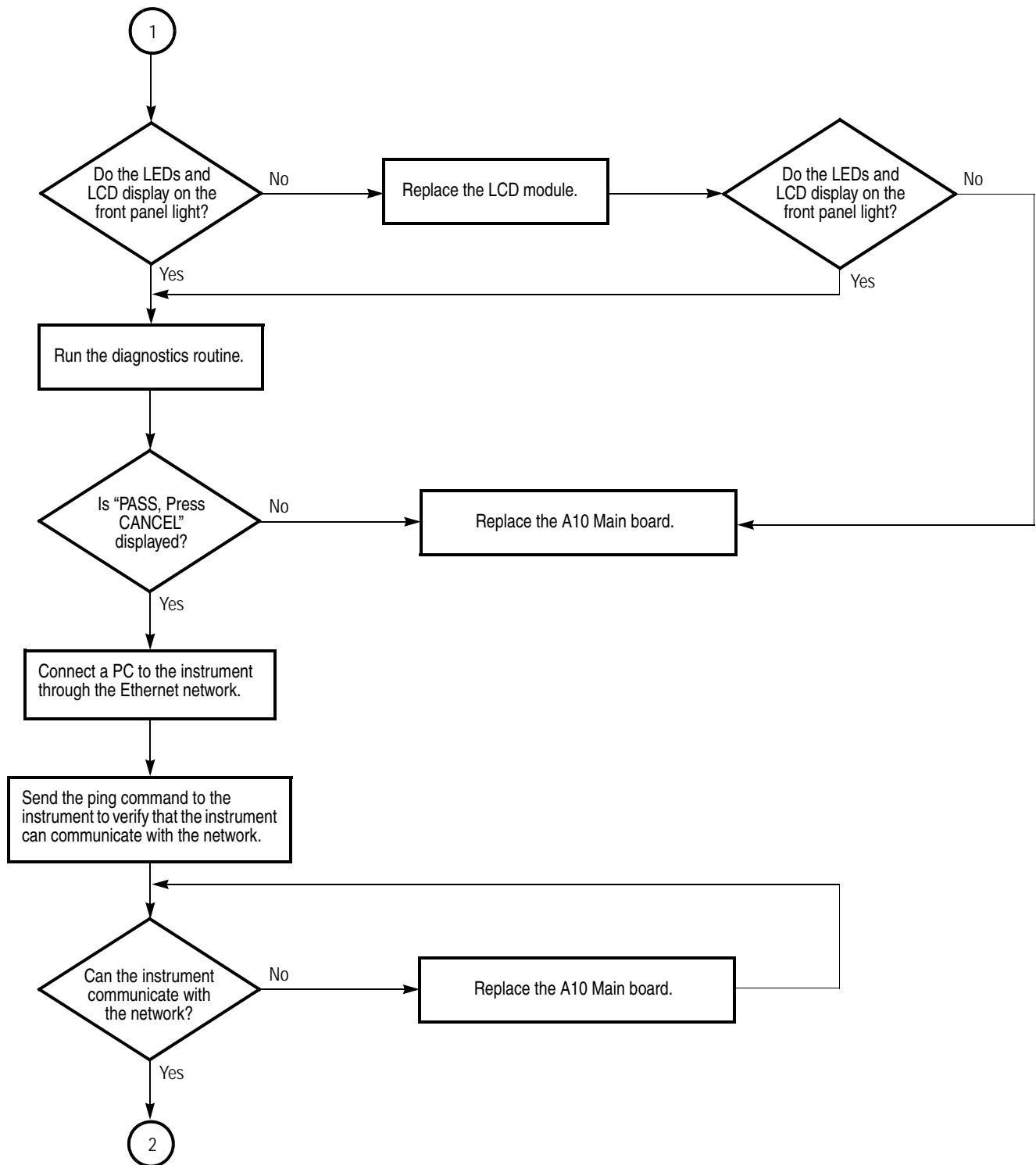

Figure 6-2: Troubleshooting procedure (2)

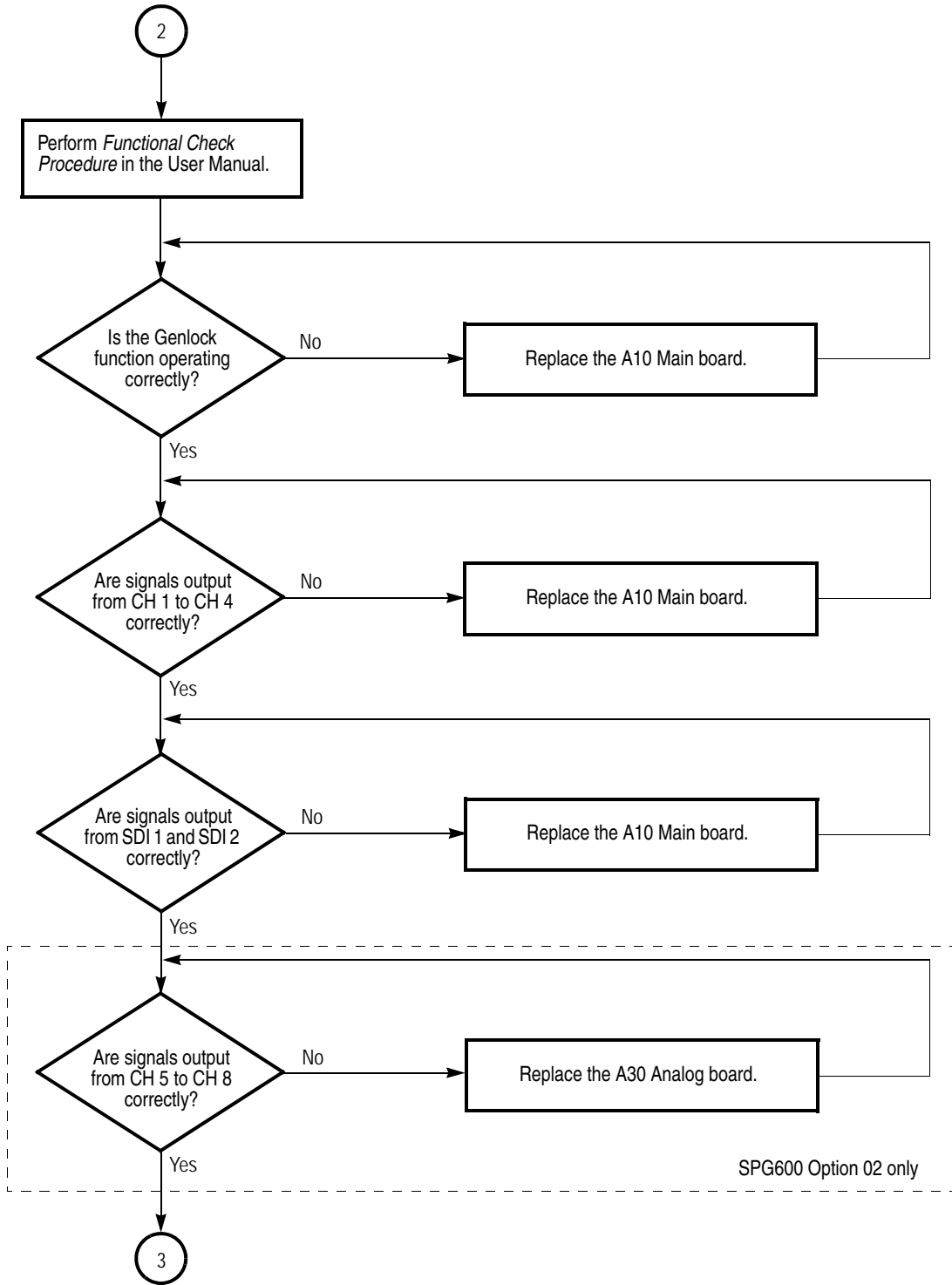

Figure 6-3: Troubleshooting procedure (3)

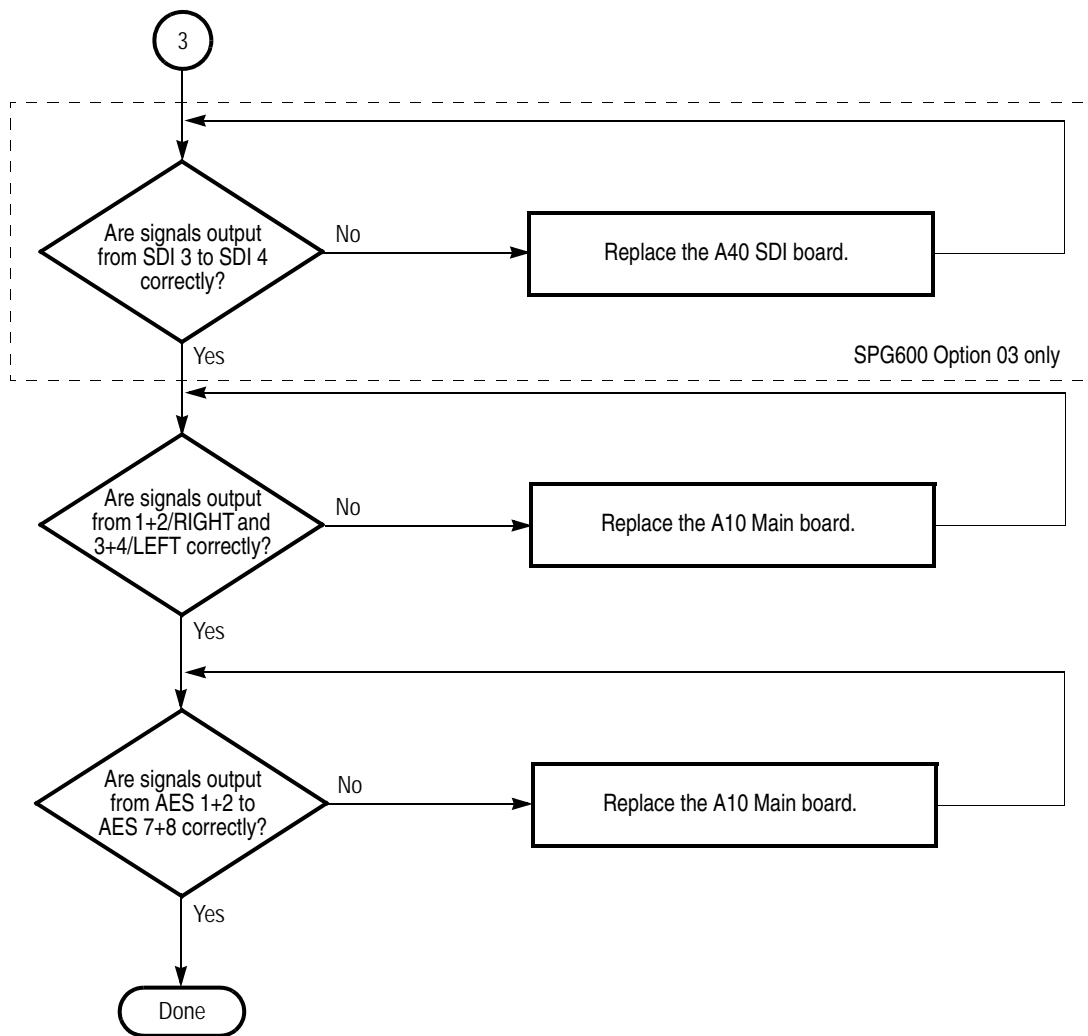

Figure 6-4: Troubleshooting procedure (4)

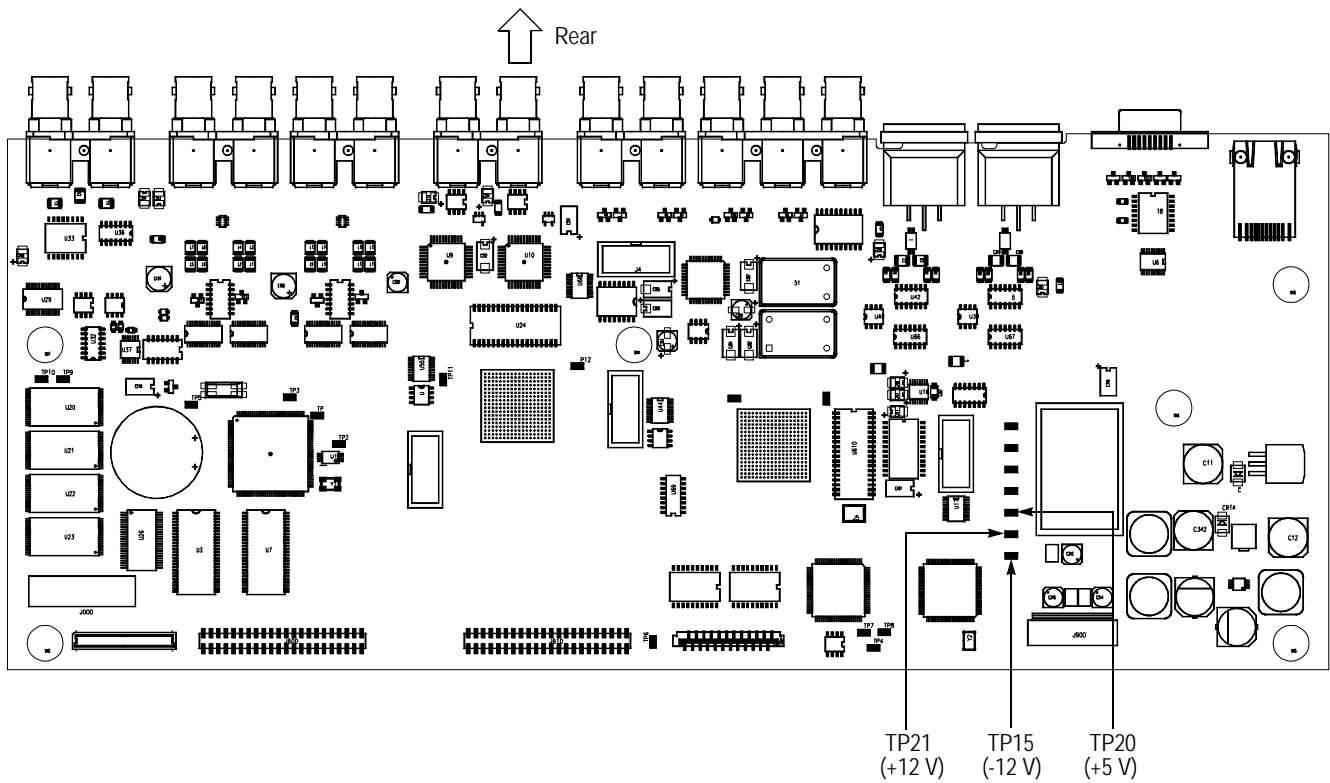

Figure 6-5: A10 Main board view of SPG600

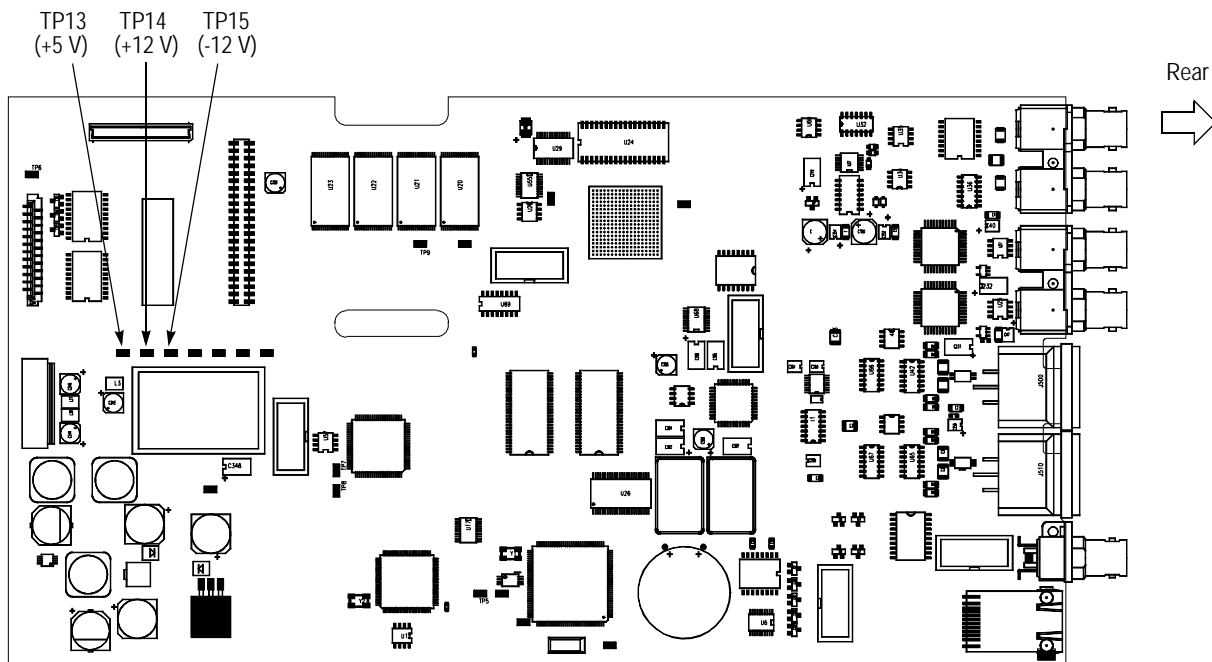

Figure 6-6: A10 Main board view of SPG300



Options

Options

This section describes additional features and options that are available for the sync pulse generator.

Additional Features

The following options provide additional capabilities to the sync pulse generator:

- **Option 01** (SPG600 and SPG300): Adds fine timing adjustment for analog outputs.
- **Option 02** (SPG600 only): Adds 4-channel analog video outputs.
- **Option 03** (SPG600 only): Adds 2-channel SD-SDI video outputs.

Service Options

The following service options are available for the sync pulse generator:

- **Option D1**: Provides calibration data.
- **Option D3**: Provides calibration data for 3 years.
- **Option D5**: Provides calibration data for 5 years.
- **Option C3**: Provides calibration services for 3 years.
- **Option C5**: Provides calibration services for 5 years.
- **Option R3**: Extends the instrument warranty to 3 years.
- **Option R5**: Extends the instrument warranty to 5 years.



Electrical Parts List



Electrical Parts List

The modules that make up this instrument are often a combination of mechanical and electrical subparts. Therefore, all replaceable modules are listed in section 10, *Mechanical Parts List*. Refer to that section for part numbers when using this manual.



Diagrams

Diagrams

This section contains the following diagrams:

- Block diagrams of the SPG600 and SPG300
- Interconnect diagrams of the SPG600 and SPG300

The Block diagrams show the modules and functional blocks in the sync pulse generators. The Interconnect diagrams show how the modules in the sync pulse generators connect together.

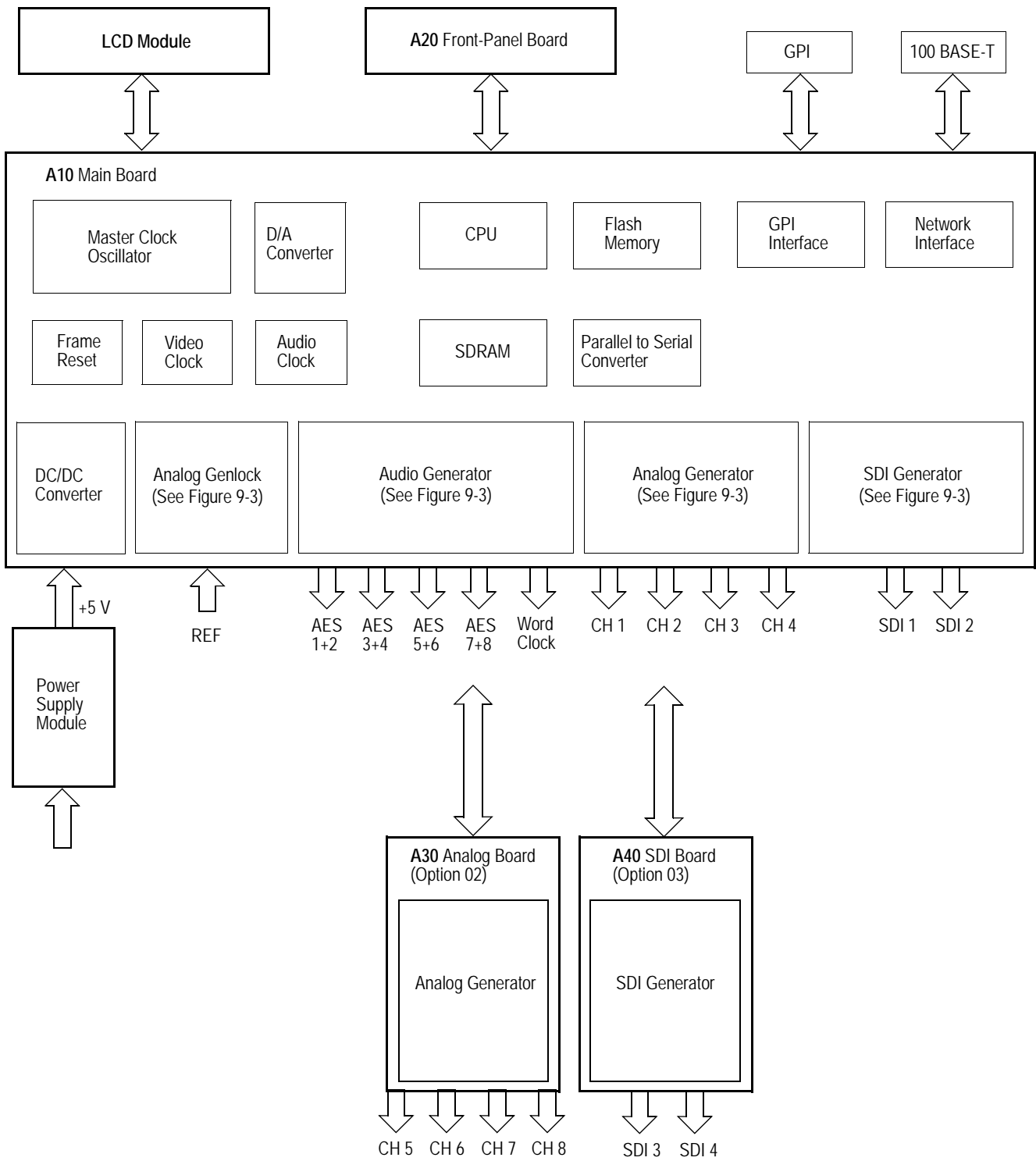

Figure 9-1: SPG600 block diagram

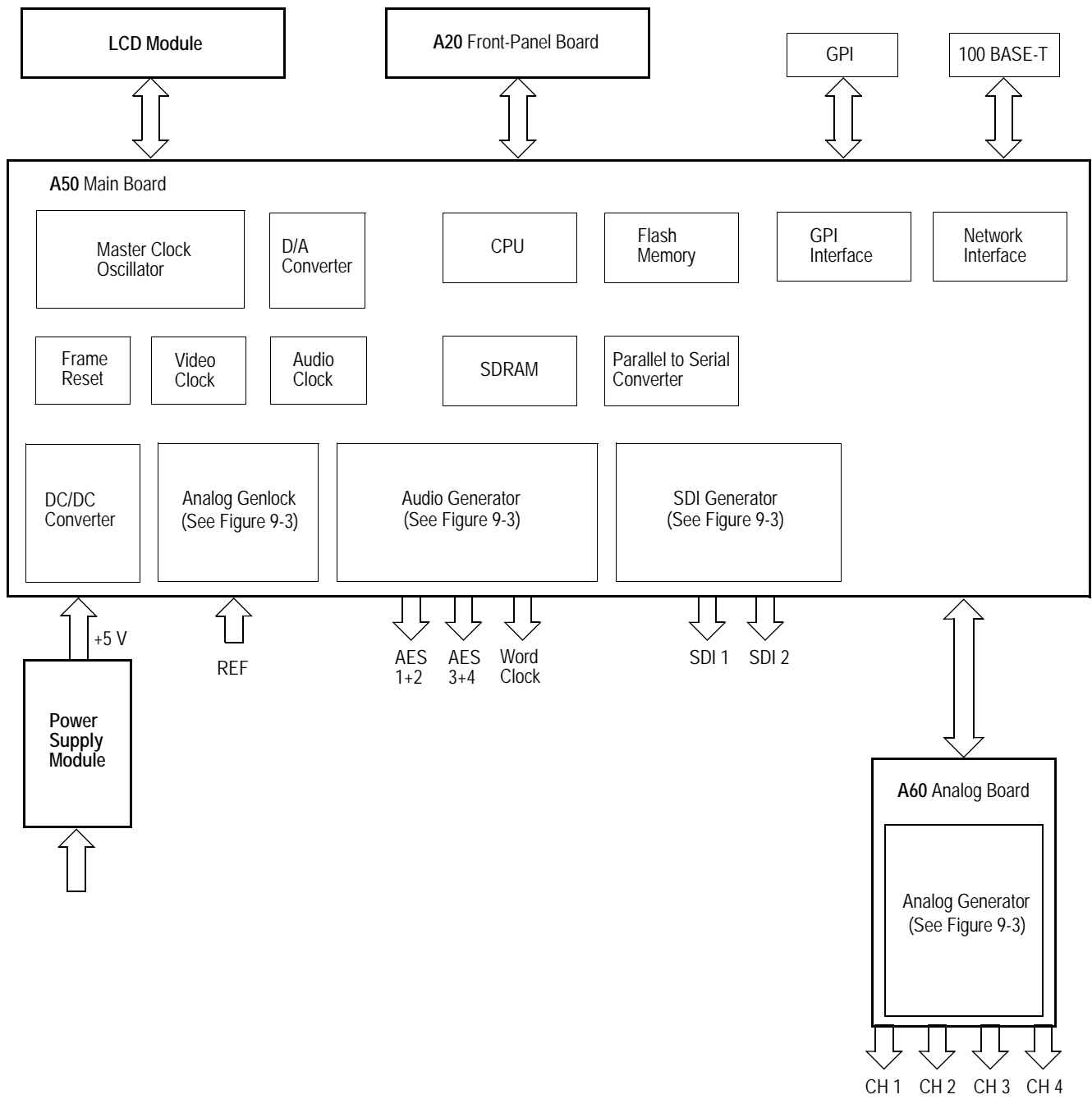

Figure 9-2: SPG300 block diagram

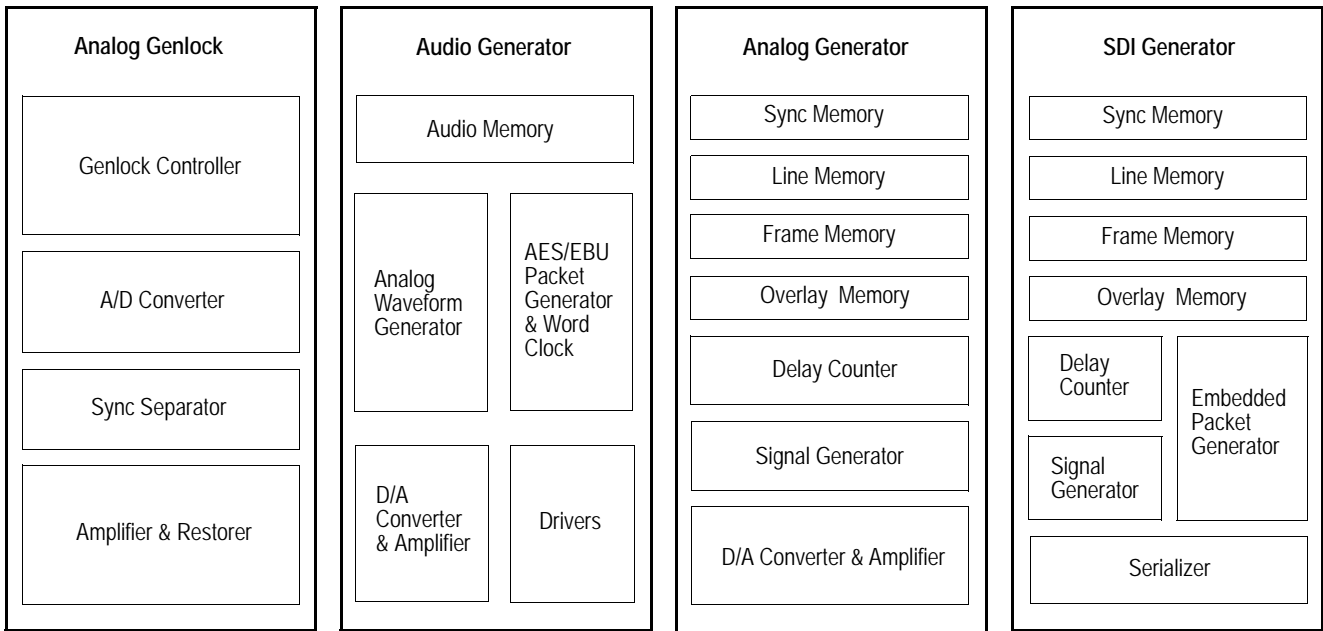

Figure 9-3: Main function block diagram

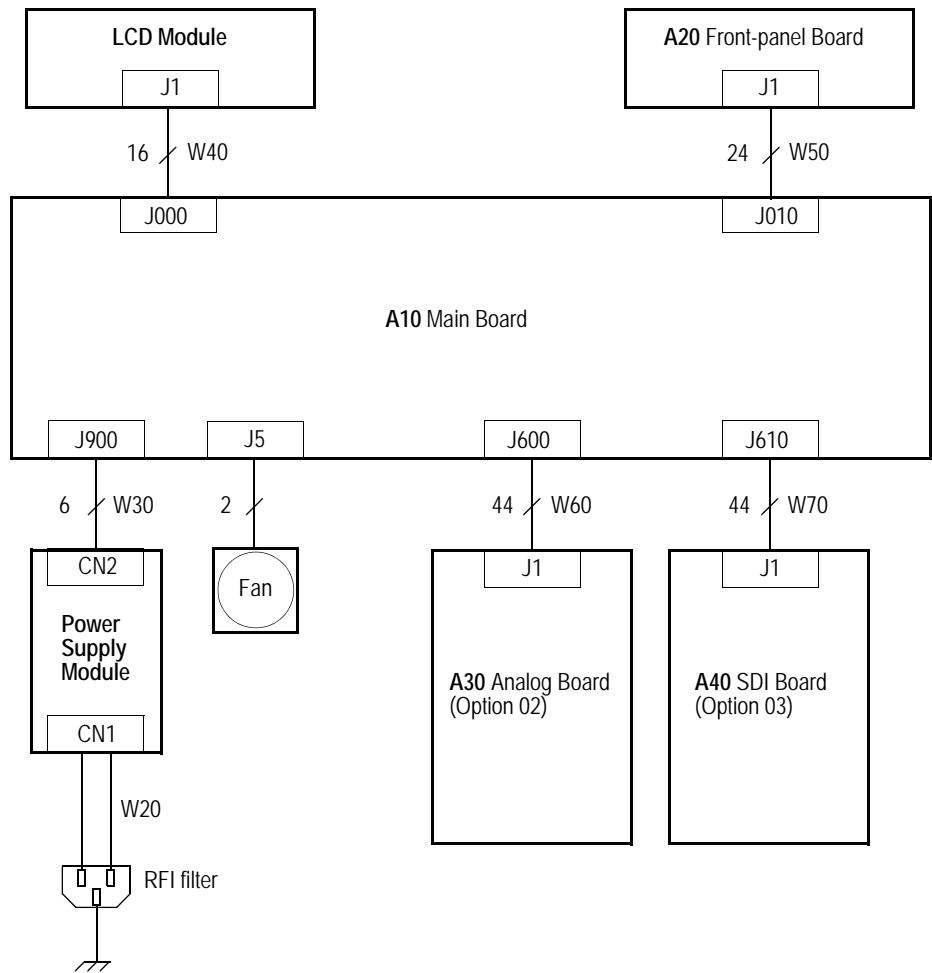

Figure 9-4: SPG600 interconnect diagram

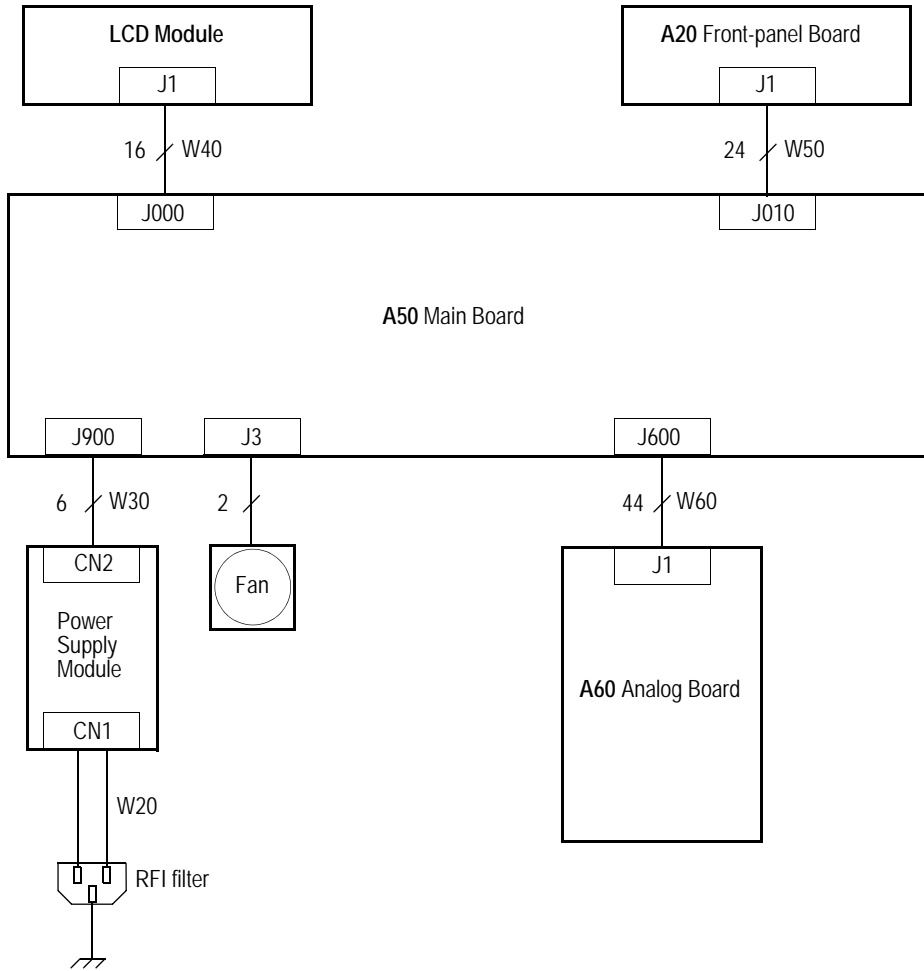

Figure 9-5: SPG300 interconnect diagram



Mechanical Parts List

Mechanical Parts List

This section contains a list of the replaceable modules for the sync pulse generator. Use this list to identify and order replacement parts.

Parts Ordering Information

Replacement parts are available through your local Tektronix field office or representative.

Change to Tektronix products are sometimes made to accommodate improved components as they become available and to give you the benefit of the latest improvements. Therefore, when ordering parts, it is important to include the following information in your order.

- Part number (see *Part Number Revision Level* below)
- Instrument type or model number
- Instrument serial number
- Instrument modification number, if applicable

If you order a part that has been replaced with a different or improved part, your local Tektronix field office or representative will contact you concerning any change in part number.

Part Number Revision Level

Tektronix part numbers contain two digits that show the revision level of the part. For most parts in this manual, you will find the letters XX in place of the revision level number.

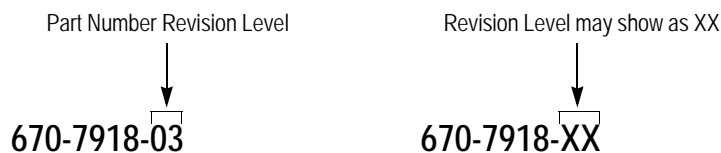

When you order parts, Tektronix will provide you with the most current part for your product type, serial number, and modification (if applicable). At the time of your order, Tektronix will determine the part number revision level needed for your product, based on the information you provide.

Module Servicing Modules can serviced by selecting one of the following three options. Contact your local Tektronix service center or representative for repair assistance.

Module Exchange. In some cases you may exchange your module for a remanufactured module. These modules cost significantly less than new modules and meet the same factory specifications. For more information about the module exchange program., call 1-800-833-9200. Outside North America, contact a Tektronix sales office or distributor; see the Tektronix web site for a list of offices: www.tektronix.com

Module Repair and Return. You may ship your module to us for repair, after which we will return it to you.

New Modules. You may purchase replacement modules in the same way as order replacement parts.

Using the Replaceable Parts List

This section contains a list of the mechanical and/or electrical components that are replaceable for the sync pulse generator. Use this list to identify and order replacement parts. The following table describes each column in the parts list.

Parts list column descriptions

Column	Column name	Description
1	Figure & Index Number	Items in this section are referenced by figure and index numbers to the exploded view illustrations that follow.
2	Tektronix Part Number	Use this part number when ordering replacement parts from Tektronix.
3 and 4	Serial Number	Column three indicates the serial number at which the part was first effective. Column four indicates the serial number at which the part was discontinued. No entries indicates the part is good for all serial numbers.
5	Qty	This indicates the quantity of parts used.
6	Name & Description	An item name is separated from the description by a colon(:). Because of space limitations, an item name may sometimes appear as incomplete. Use the U.S Federal Catalog handbook H6-1 for further item name identification.
7	Mfr. Code	This indicates the code of the actual manufacturer of part.
8	Mfr. Part Number	This indicates the actual manufacturer's or Vendor's part number.

Abbreviations Abbreviations conform to American National Standard ANSI Y1.1-1972.

**Mfr. Code to Manufacturer
Cross Index**

The table titled *Manufacturers cross index* shows codes, names, and addresses of manufacturers or vendors of components listed in the parts list.

Manufacturers cross index

Mfr. code	Manufacturer	Address	City, state, zip code
S3109	FELLER	72 VERONICA AVE UNIT 4	SUMMERSET NJ 08873
TK2432	UNION ELECTRIC	15/F #1, FU-SHING N. ROAD	TAIPEI, TAIWAN ROC
2W733	BELDEN CORPORATION	2200 US HIGHWAY 27 SOUTH PO BOX 1980	RICHMOND IN 47375-0010
80009	TEKTRONIX INC	14150 SW KARL BRAUN DR PO BOX 500	BEAVERTON, OR 97077-0001

Replaceable parts list (SPG600)

Fig. & index number	Tektronix part number	Serial no. effective	serial no. discont'd	Qty	Name & description	Mfr. code	Mfr. part number
10-1-1	378-0460-00			1	FILTER	80009	
10-1-2	211-A245-00			4	SCREW,MACHINE:M3X6MM L,PNH,STL,NI PL,CROSS REC, W/KOGATAMARU & LOCK WASHER	80009	
10-1-3	119-6943-00			1	LCD:GPC202-555-NGPBERY	80009	
10-1-4	131-7617-00			1	CONN,HDR:PCB,MLE,STR,2X8,0.1 CTR	80009	
10-1-5	211-A268-00			16	SCREW,MACHINE,M3X6MM L,FLH,STL,NI,CROSS REC	80009	
10-1-6	200-4852-00			1	COVER, TOP	80009	
10-1-7	335-1199-00			1	WARNING LABEL	80009	
10-1-8	211-A266-00			2	SCREW,MACHINE:M3X12MM L,PNH,STL,NI PL,CROSS REC, W/KOGATAMARU & LOCK WASHER	80009	
10-1-9	131-4131-00			1	CONN,PLUG,ELEC:MALE W/LOCKING ADPTR,EXT MTG	80009	
10-1-10	119-6009-00			1	FILTER,RFI:3A,250VAC,0.5MA,0.15OHM	80009	
10-1-11	195-3990-00			1	LEAD,ELECTRICAL:AWG18,100MM L,5-4,W/LUG	80009	
10-1-12	441-2353-00			1	CHASSIS,MAIN	80009	
10-1-13	334-1378-50			1	MARKER,IDENT:MKD SERIAL NO. FOR TEKTRONIX JAPAN	80009	
10-1-14	671-5774-00			1	CIRCUIT BOARD ASSY:A20 FRONT PANEL,FR-4,8L, 389-3541-00 WIRED	80009	
10-1-15	260-2787-00			1	SWITCH	80009	
10-1-16	211-A245-00			2	SCREW,MACHINE:M3X6MM L,CROSS REC,W/KOGATAMARU & LOCK WASHER	80009	
10-1-17	101-0166-00			1	TRIM,FRONT	80009	

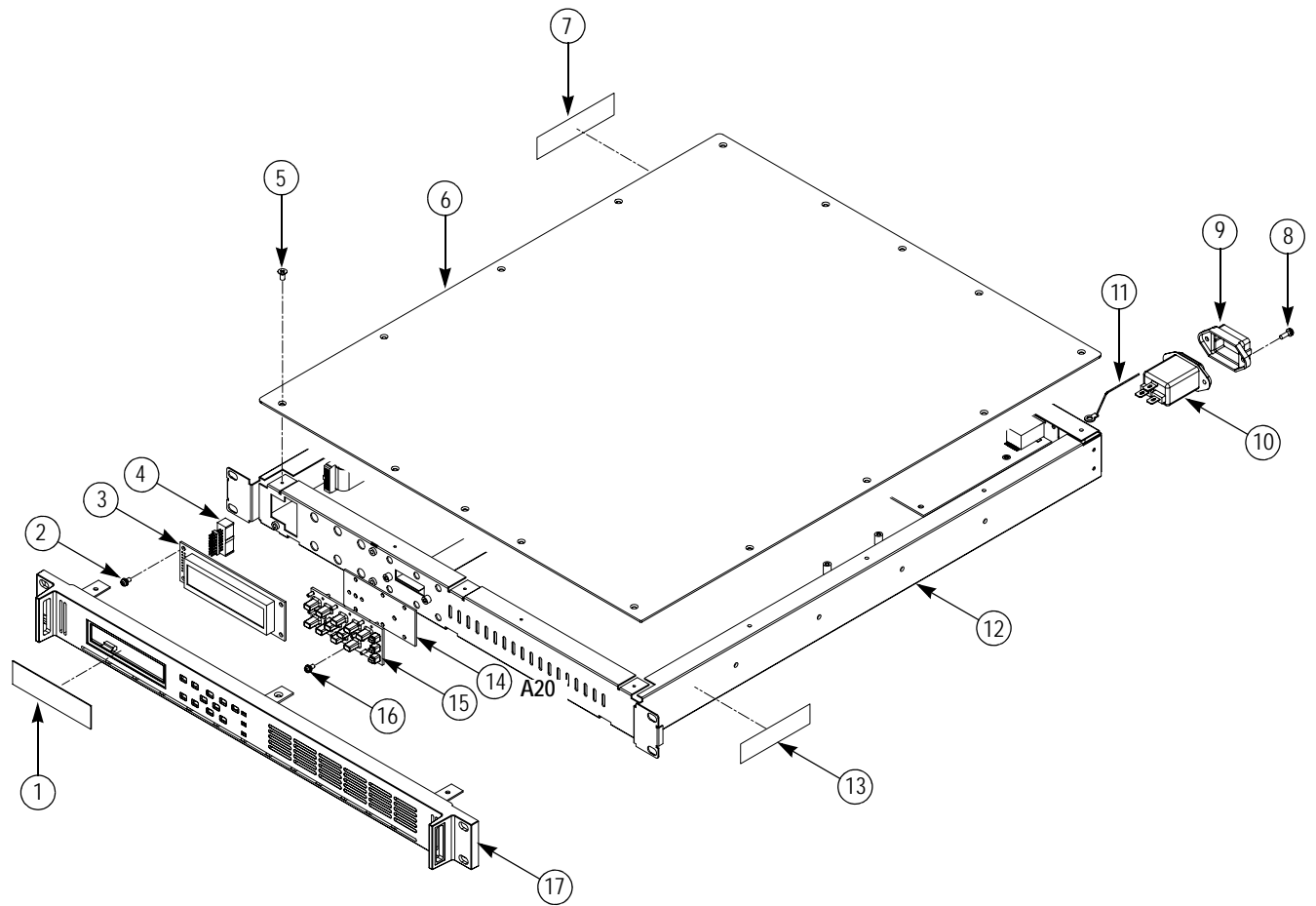

Figure 10-1: SPG600 external modules

Replaceable parts list (SPG600)

Fig. & index number	Tektronix part number	Serial no. effective	serial no. discont'd	Qty	Name & description	Mfr. code	Mfr. part number
10-2-1	174-4929-00			1	CABLE ASSEMBLY: W60,A10 TO OP-BD	80009	
10-2-2	129-1605-00			2	SPACER,POST: 19.0MM L,M3 THRU,5.5MM HEX,BRS NI PL	80009	
10-2-3	211-A245-00			2	SCREW,MACHINE: M3X6MM L,PNH,STL,NI,CROSS REC, W/KOGATAMARU & LOCK WASHER	80009	
10-2-4	671-5775-00			1	CIRCUIT BOARD ASSY:A30 ANALOG,FR-4,8L,389-3542-00 WIRED	80009	
10-2-5	211-A245-00			4	SCREW,MACHINE: M3X6MM L,PNH,STL,NI,CROSS REC, W/KOGATAMARU & LOCK WASHER	80009	
10-2-6	407-5015-00			1	BRACKET,A40 389-3543-00	80009	
10-2-7	671-5776-00			1	CIRCUIT BOARD ASSY:A40	80009	
10-2-8	129-1605-00			2	SPACER,POST: 19.0MM L,M3 THRU,5.5MM HEX,BRS NI PL	80009	
10-2-9	174-4929-00			1	CABLE ASSEMBLY: W60,A10 TO OP-BD	80009	
10-2-10	211-A245-00			6	SCREW,MACHINE: M3X6MM L,PNH,STL,NI,CROSS REC, W/KOGATAMARU & LOCK WASHER	80009	
10-2-11	337-4313-00			1	SHIELD,ELEC: REAR,SPG600	80009	
10-2-12	671-5773-05			1	CIRCUIT BOARD ASSY:A10 MAIN,FR-4,8L,389-3540-00 WIRED	80009	
10-2-13	174-4926-00			1	CABLE ASSEMBLY: W30PS TO A10	80009	
10-2-14	348-1332-00			1	PAD,CUSHIONING	80009	
10-2-15	211-A235-00			2	SCREW,MACHINE: M3X40MM L,PNH,STL,ZN-C,CROSS REC,W/M PLAIN&SPLIT WASHER	80009	
10-2-16	200-4943-00			1	GUARD,FAN: AL	80009	
10-2-17	129-1615-00			2	CL-307N		
10-2-18	119-B059-00			1	FAN,TUBE AXIAL: 119-B055-00 W/CONN,10CM L	80009	
10-2-19	211-A234-00			1	SCREW,MACHINE: M3X35MM L,PNH,STL,ZN-C,CROSS REC,W/M PLAIN&SPLIT WASHER	80009	
10-2-20	337-4312-00			1	SHIELD ELEC: POWER SUPPLY	80009	
10-2-21	174-4925-00			1	CABLE ASSEMBLY: W20,INLET TO PS	80009	
10-2-22	119-6942-00			1	POWER SUPPLY: LDC30F-1-SN	80009	
10-2-23	221-A245-00			4	SCREW,MACHINE: M3X6MM L,PNH,STL,NI,CROSS REC, W/KOGATAMARU & LOCK WASHER	80009	
10-2-24	211-A218-00			13	SCREW,MACHINE: M2.6X6MM L,PNH,STL,ZN-C,CROSS REC W/LOCK&FLAT	80009	
10-2-25	386-7399-00			1	PANEL,BLANK	80009	
10-2-26	174-4927-00			1	CABLE ASSEMBLY: W50 A10 TO SW	80009	
10-2-27	211-0945-00			2	SCREW,MACHINE: M4X8MM L,STL,ZN-C,CROSS REC	80009	
10-2-28	210-0008-00			2	WASHER,LOCK: #8 INTL,0.02 THK,STL CD PL	80009	
10-2-29	343-1707-00			3	CLAMP,CABLE: NYLON	80009	
10-2-30	174-4928-00			1	CABLE ASSEMBLY: W40,A10 TO LCD	80009	

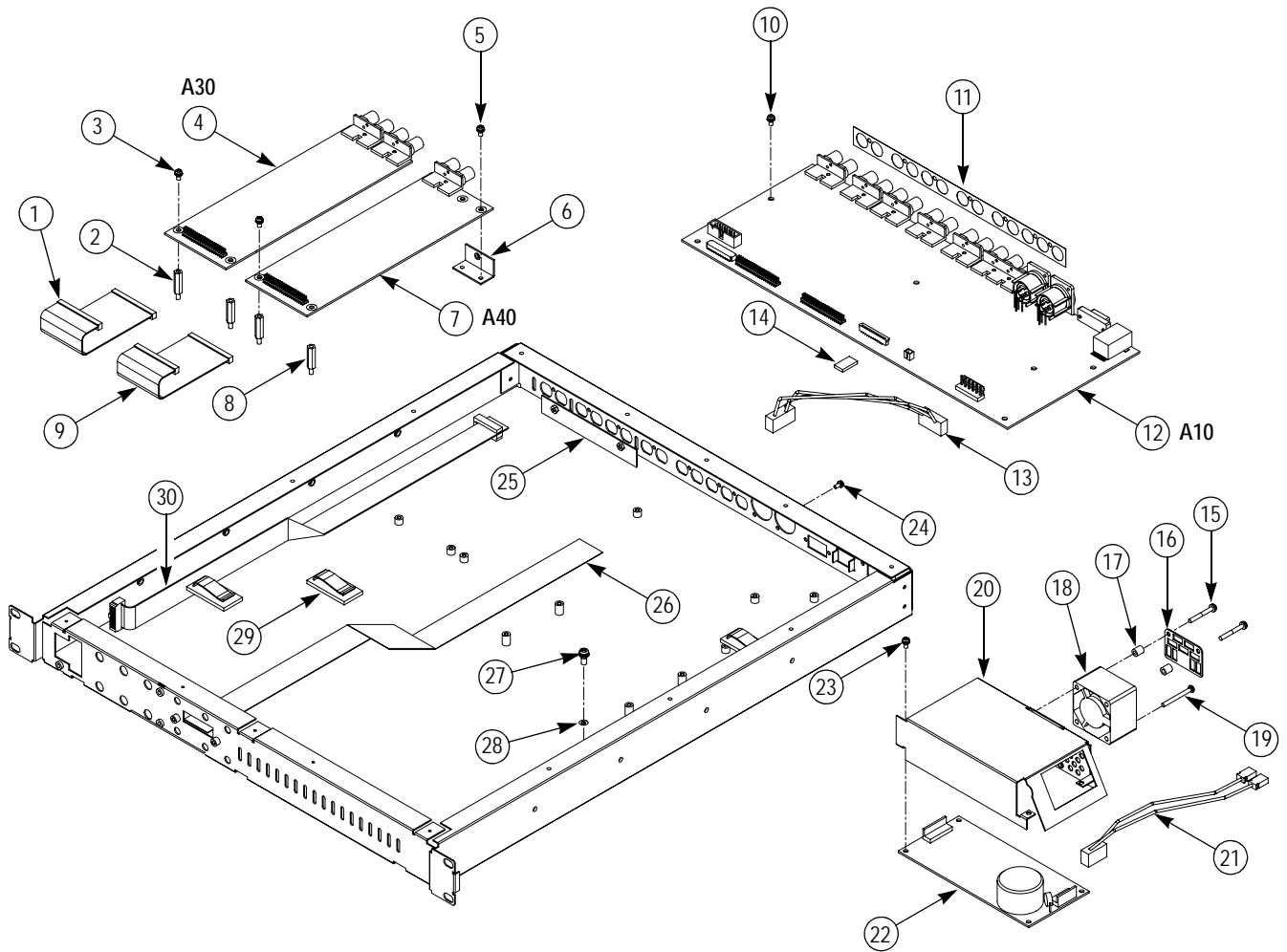

Figure 10-2: SPG600 internal modules

Replaceable parts list (SPG300)

Fig. & index number	Tektronix part number	Serial no. effective	serial no. discont'd	Qty	Name & description	Mfr. code	Mfr. part number
10-3-1	335-1134-00			1	MARKER,IDENT: MKD SPG300 TEK JAPAN	80009	
10-3-2	378-0460-00			1	FILTER	80009	
10-3-3	441-2363-00			1	CHASSIS,FRONT	80009	
10-3-4	119-6943-00			1	LCD:GPC202-555-NGPBERY	80009	
10-3-5	131-7617-00			1	CONN,HDR:PCB,MLE,STR,2X8,0.1 CTR	80009	
10-3-6	211-A245-00			4	SCREW,MACHINE:M3X6MM L,PNH,STL,NI,PL,CROSS REC, W/KOGATAMARU & LOCK WASHER	80009	
10-3-7	211-1194-00			13	SCREW: M3X6MM L,FLH,STL ZN PL BLACK,CROSS REC	80009	
10-3-8	200-4875-00			1	COVER,TOP	80009	
10-3-9	335-1199-00			1	WARNING LABEL	80009	
10-3-10	174-4994-00			1	CONN,D-SUB	80009	
10-3-11	210-A007-00			2	WASHER,PLAIN: #3,6MM OD,STL MFZN-C,KOGATAMARU	80009	
10-3-12	210-A015-00			2	WASHER,LOCK: #3,SPLIT,STL MFZN-C	80009	
10-3-13	214-3903-01			2	SCREW,JACK: 4-40X0.312 EXT THD,4-40 INT THD,0.188 HEX,STEEL,CAD PLATE	80009	
10-3-14	119-6009-00			1	FILTER,RFI:3A,250VAC,0.5MA,0.15OHM	80009	
10-3-15	131-4131-00			1	CONN,PLUG,ELEC:MALE W/LOCKING ADPTR,EXT MTG	80009	
10-3-16	211-A266-00			2	SCREW,MACHINE:M3X12MM L,PNH,STL,NI PL,CROSS REC, W/KOGATAMARU & LOCK WASHER	80009	
10-3-17	195-3990-00			1	LEAD,ELECTRICAL:AWG18,100MM L,5-4,W/LUG	80009	
10-3-18	334-1378-50			1	MARKER,IDENT:MKD SERIAL NO. FOR TEKTRONIX JAPAN	80009	
10-3-19	441-2364-00			1	CHASSIS,MAIN	80009	
10-3-20	211-A245-00			6	SCREW,MACHINE:M3X6MM L,PNH,STL,NI,PL,CROSS REC, W/KOGATAMARU & LOCK WASHER	80009	
10-3-21	671-5774-00			1	CIRCUIT BOARD ASSY:A20 FRONT PANEL,FR-4,8L, 389-3541-00 WIRED	80009	
10-3-22	260-2787-00			1	SWITCH	80009	

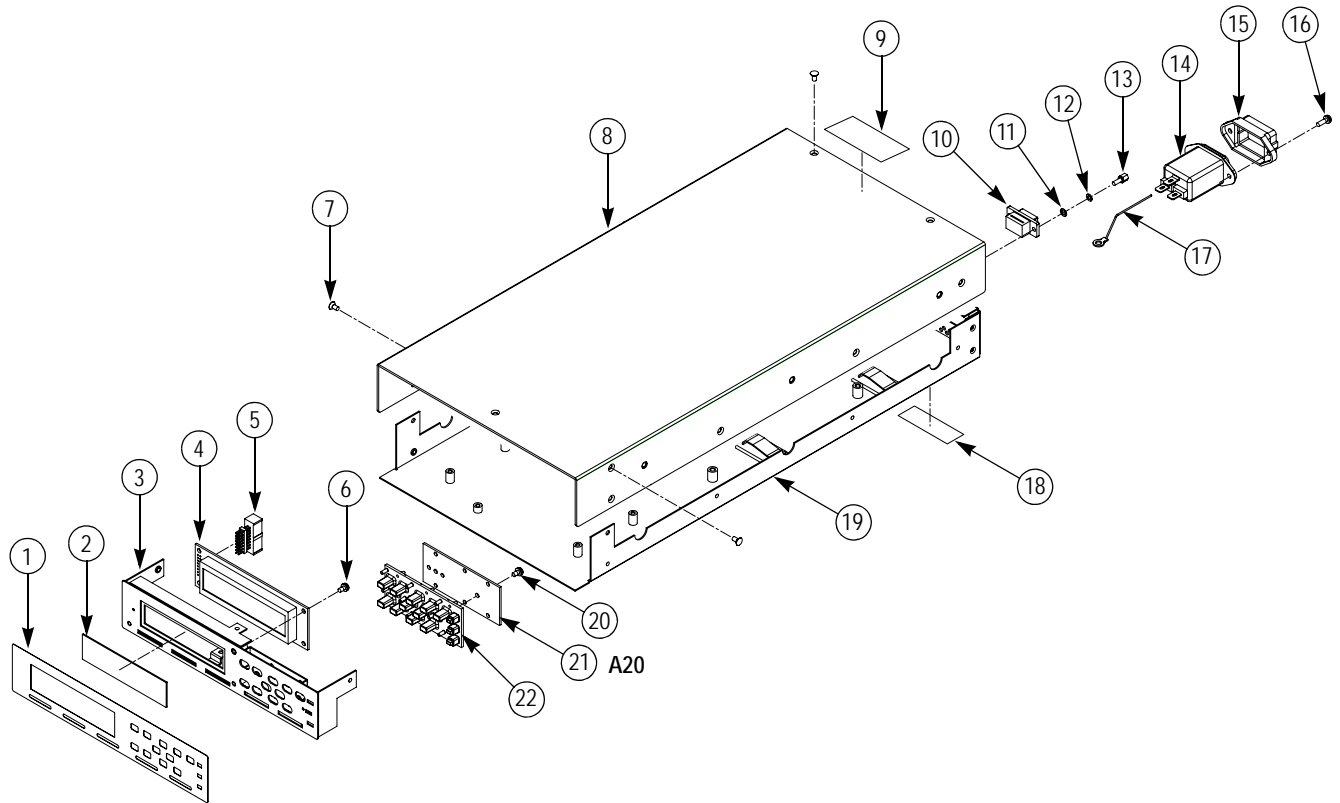

Figure 10-3: SPG300 external modules

Replaceable parts list (SPG300)

Fig. & index number	Tektronix part number	Serial no. effective	serial no. discont'd	Qty	Name & description	Mfr. code	Mfr. part number
10-4-1	174-4997-00			1	CABLE ASSEMBLY: W50 A10 TO SW	80009	
10-4-2	174-4995-00			1	CABLE ASSEMBLY: W40,A10 TO LCD	80009	
10-4-3	174-4996-00			1	CABLE ASSEMBLY: W60,A50 TO OP-BD	80009	
10-4-4	211-A245-00			2	SCREW,MACHINE: M3X6MM L,PNH,STL,NI,CROSS REC, W/KOGATAMARU & LOCK WASHER	80009	
10-4-5	671-5826-00			1	CIRCUIT BOARD ASSY:A60 389-3542-00	80009	
10-4-6	211-A218-00			2	SCREW,MACHINE: M2.6X6MM L,PNH,STL,ZN-C,CROSS REC W/LOCK&FLAT	80009	
10-4-7	337-4314-00			1	SHIELD,ELEC: REAR,SPG300	80009	
10-4-8	211-A218-00			3	SCREW,MACHINE: M2.6X6MM L,PNH,STL,ZN-C,CROSS REC W/LOCK&FLAT	80009	
10-4-9	211-A218-00			4	SCREW,MACHINE: M2.6X6MM L,PNH,STL,ZN-C,CROSS REC W/LOCK&FLAT	80009	
10-4-10	671-5777-06			1	CIRCUIT BOARD ASSY:A50 MAIN BOARD,FR-4, 8/389-3544-00 WIRED	80009	
10-4-11	211-A245-00			5	SCREW,MACHINE: M3X6MM L,PNH,STL,NI,CROSS REC, W/KOGATAMARU & LOCK WASHER	80009	
10-4-12	348-1332-00			1	PAD,CUSHIONING	80009	
10-4-13	343-1707-00			3	CLAMP,CABLE: NYLON	80009	
10-4-14	210-0008-00			2	WASHER,LOCK: #8 INTL,0.02 THK,STL CD PL	80009	
10-4-15	211-0945-00			2	SCREW,MACHINE: M4X8MM L,STL,ZN-C,CROSS REC	80009	
10-4-16	174-4926-00			1	CABLE ASSEMBLY: W30,PS TO A10	80009	
10-4-17	119-B059-00			1	FAN,TUBE AXIAL: 119-B055-00 W/CONN,10CM L	80009	
10-4-18	129-1615-00			2	CL-307N	80009	
10-4-19	211-A235-00			2	SCREW,MACHINE: M3X40MM L,PNH,STL,ZN-C,CROSS REC,W/M PLAIN&SPLIT WASER	80009	
10-4-20	200-4917-00			1	GUARD,FAN;AL	80009	
10-4-21	211-A234-00			1	SCREW,MACHINE: M3X35MM L,PNH,STL,ZN-C,CROSS REC,W/M PLAIN&SPLIT WASER	80009	
10-4-22	174-5000-00			1	CABLE ASSEMBLY: W20,INLET TO PS	80009	
10-4-23	119-6942-00			1	POWER SUPPLY: LDC30F-1-SN	80009	
10-4-24	337-4312-00			1	SHIELD ELEC: POWER SUPPLY	80009	
10-4-25	211-A245-00			4	SCREW,MACHINE: M3X6MM L,PNH,STL,NI,CROSS REC, W/KOGATAMARU & LOCK WASHER	80009	

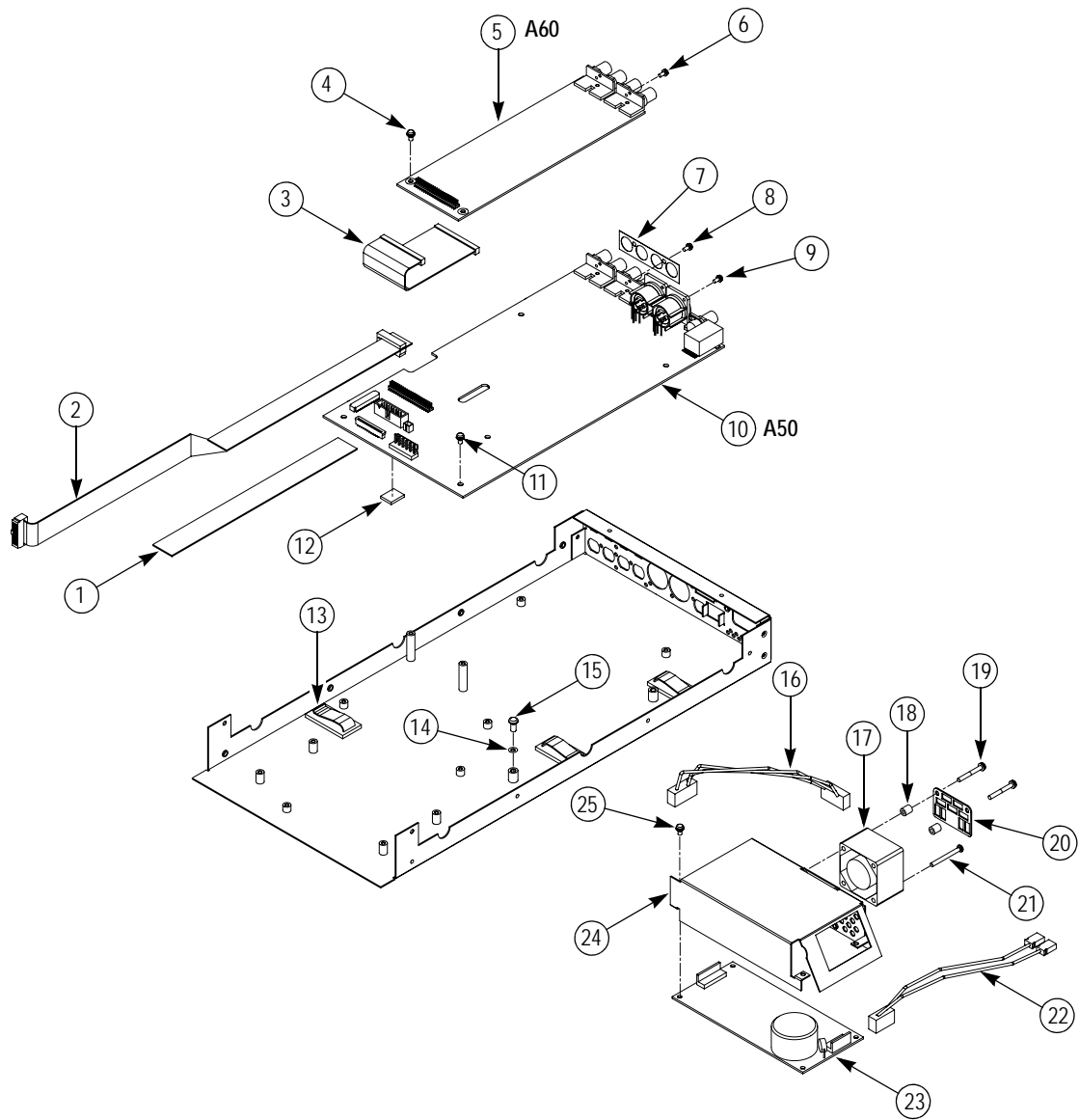

Figure 10-4: SPG300 internal modules

Replaceable parts list

Fig. & index number	Tektronix part number	Serial no. effective	serial no. discont'd	Qty	Name & description	Mfr. code	Mfr. part number
STANDRD ACCESSORIES							
	071-1341-XX			1	MANUAL,TECH:QUICK REFERENCE	80009	
	063-3685-XX			1	SOFTWARE,CD-ROM	80009	
	161-0216-00			1	CABLE ASSY,PWR;3.18 AWG,2.5M,BLACK (STANDARD ONLY)	80009	
OPTIONAL ACCESSORIES							
	070-1340-XX			1	MANUAL,TECH:USER (PRINTED MANUAL)	80009	
	070-1342-XX			1	MANUAL,TECH:SERVICE	80009	
RACKMOUNT KIT (SPG300 ONLY)							
	TVGF11A			1	RACKMOUNT KIT	80009	
	TVGF13			1	RACKMOUNT KIT	80009	